

公差表				單位	材質	機種	S510	品名
Unspecified tolerance				mm	MAT.	MODEL NAME		PART NAME
LENGTH	TOLERANCE			比例	版本	日期	審核	設計
	A class	B class	C class	SCALE	VERSION	DATE	CHK.BY	DES.BY
0 -6mm	±0.10mm	±0.05mm	±0.10mm	1:1	V0	2020/04/22	Stanley Hsia	HW CHAO
>6 -30mm	±0.15mm	±0.10mm						
>30 -100mm	±0.20mm	±0.15mm						
>100 -180mm	±0.25mm	±0.20mm						
>180 -300mm	±0.30mm	±0.25mm						
>300 -400mm	±0.50mm	±0.30mm						
Plastic Parts Angle ±0.5°				SHEET 1 OF 2		Stanley Hsia		HW CHAO
Metal Parts Angle ±1°								HW CHAO

註記	日期	內容	簽署
MARKING	DATE	DESCRIPTION	SIGNATURE

註：1. 金手指PCB類,未標註之尺寸公差為±0.12mm,其它PCB類及其它機構件未標註之公差即公差表。
 NOTE : 1. For PCB with golden finger, unspecified tolerance is ±0.12mm, other kinds of PCB and mechanical parts, unspecified tolerance see tolerance table.

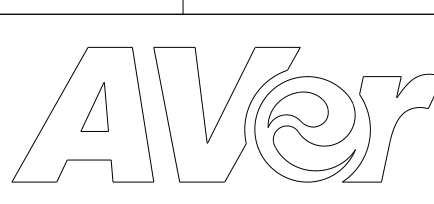

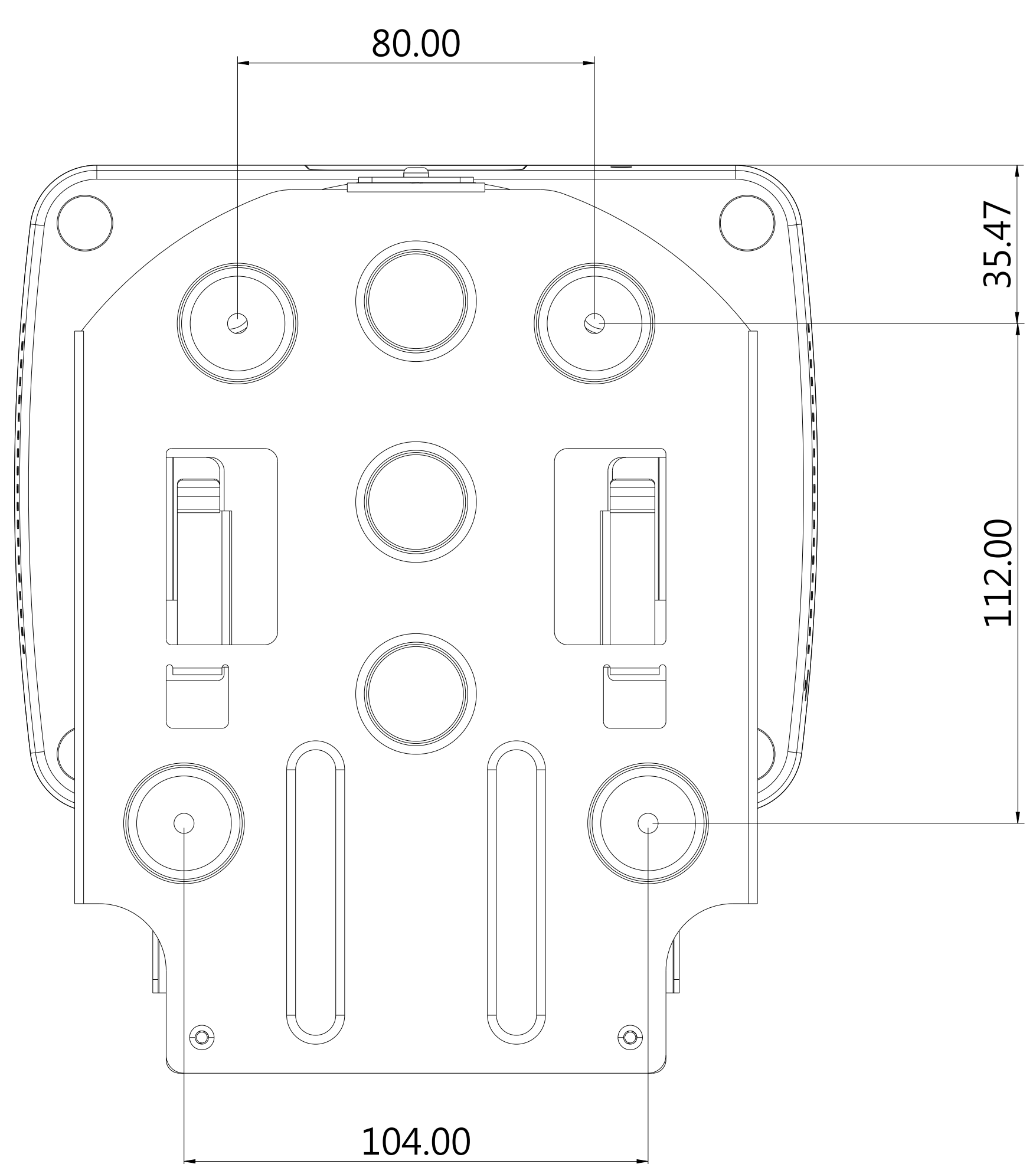
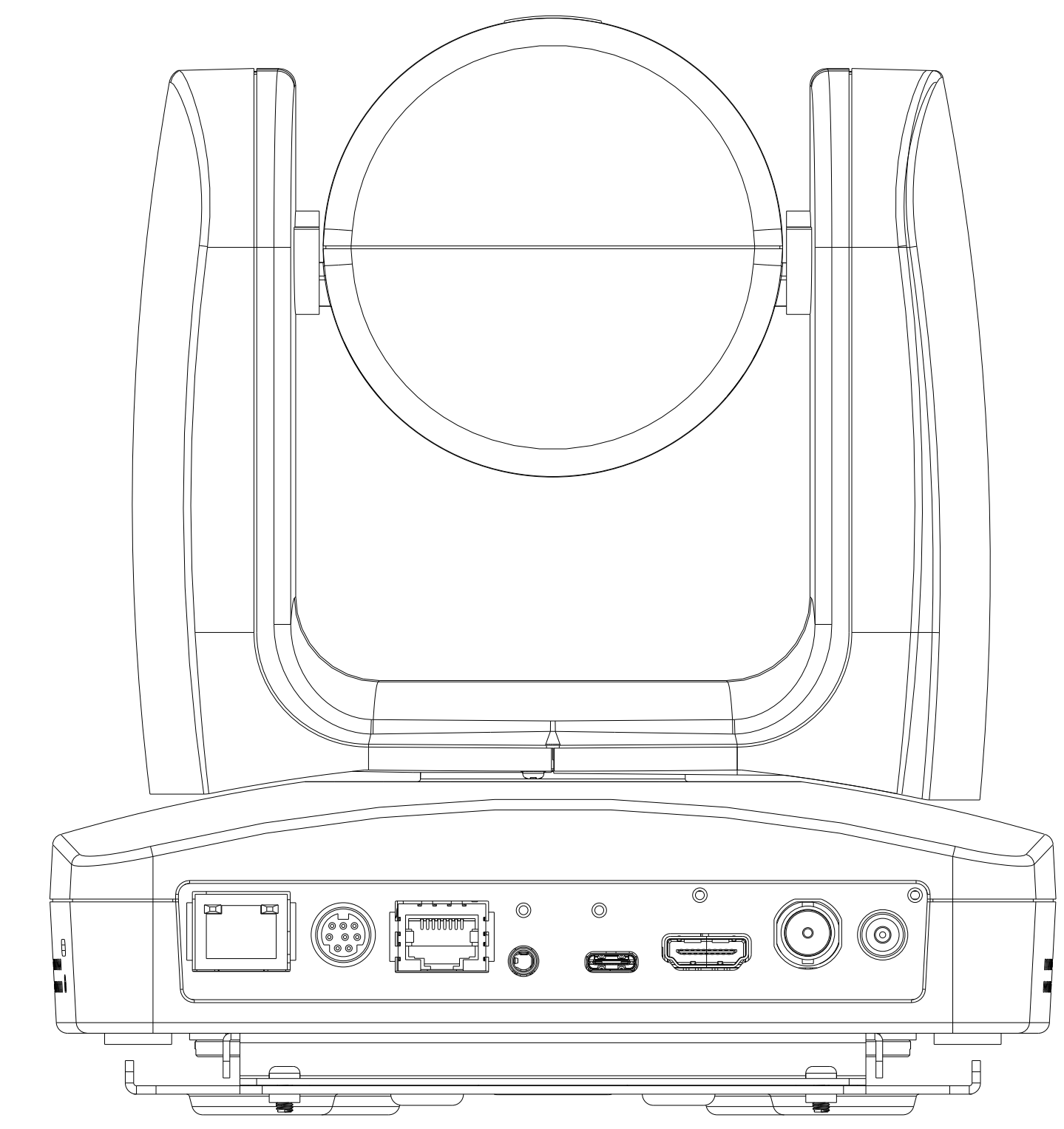
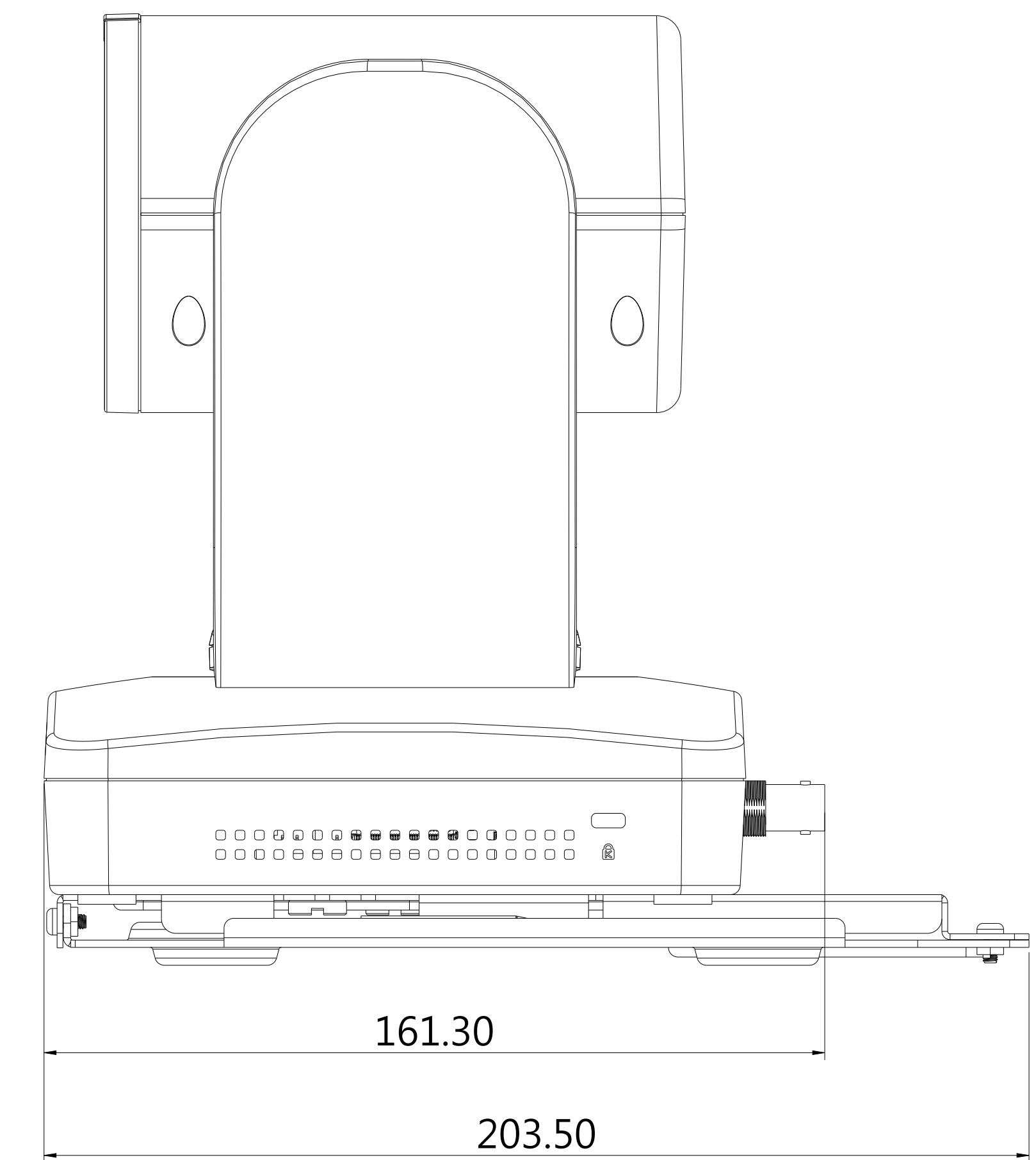
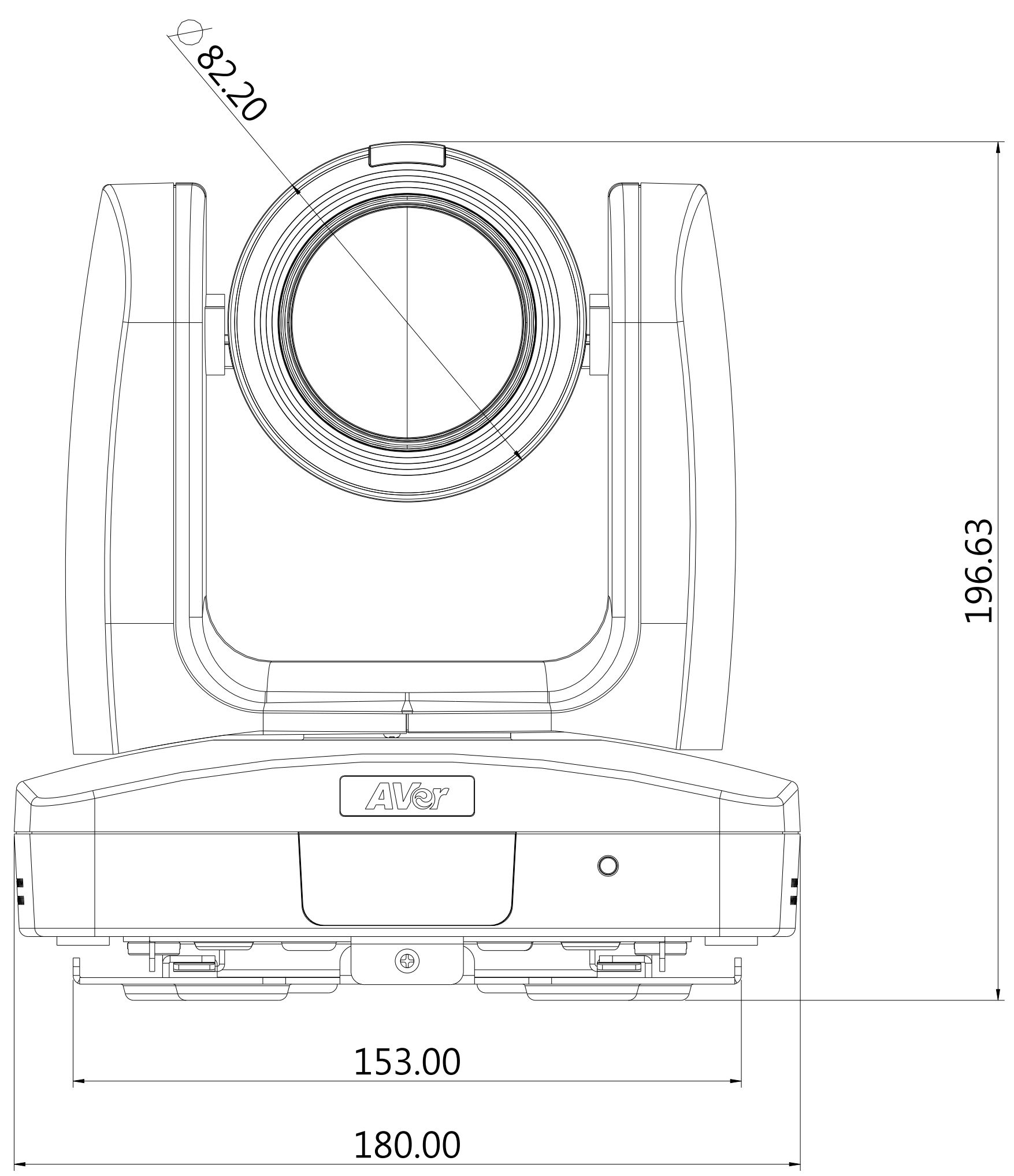
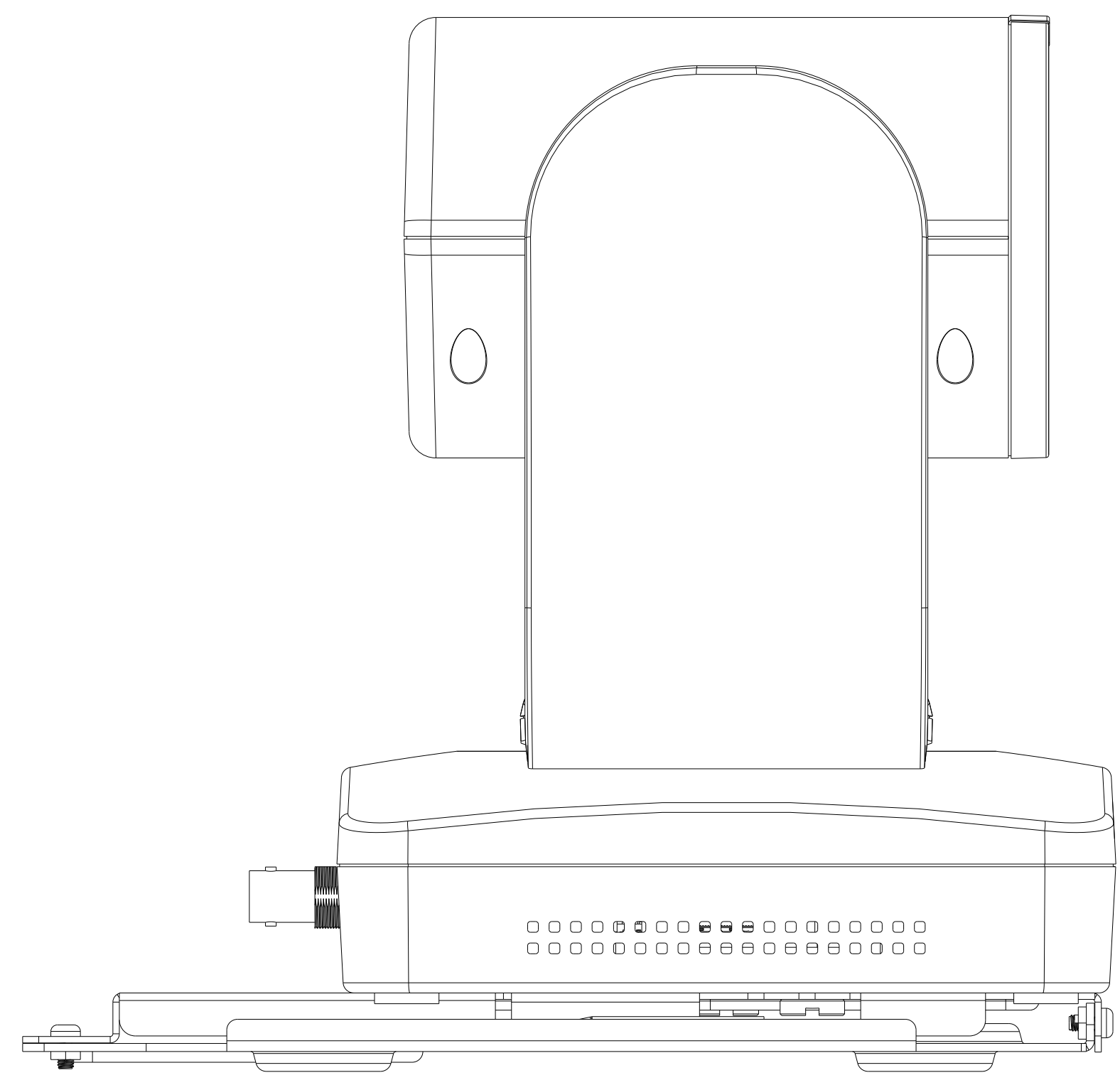
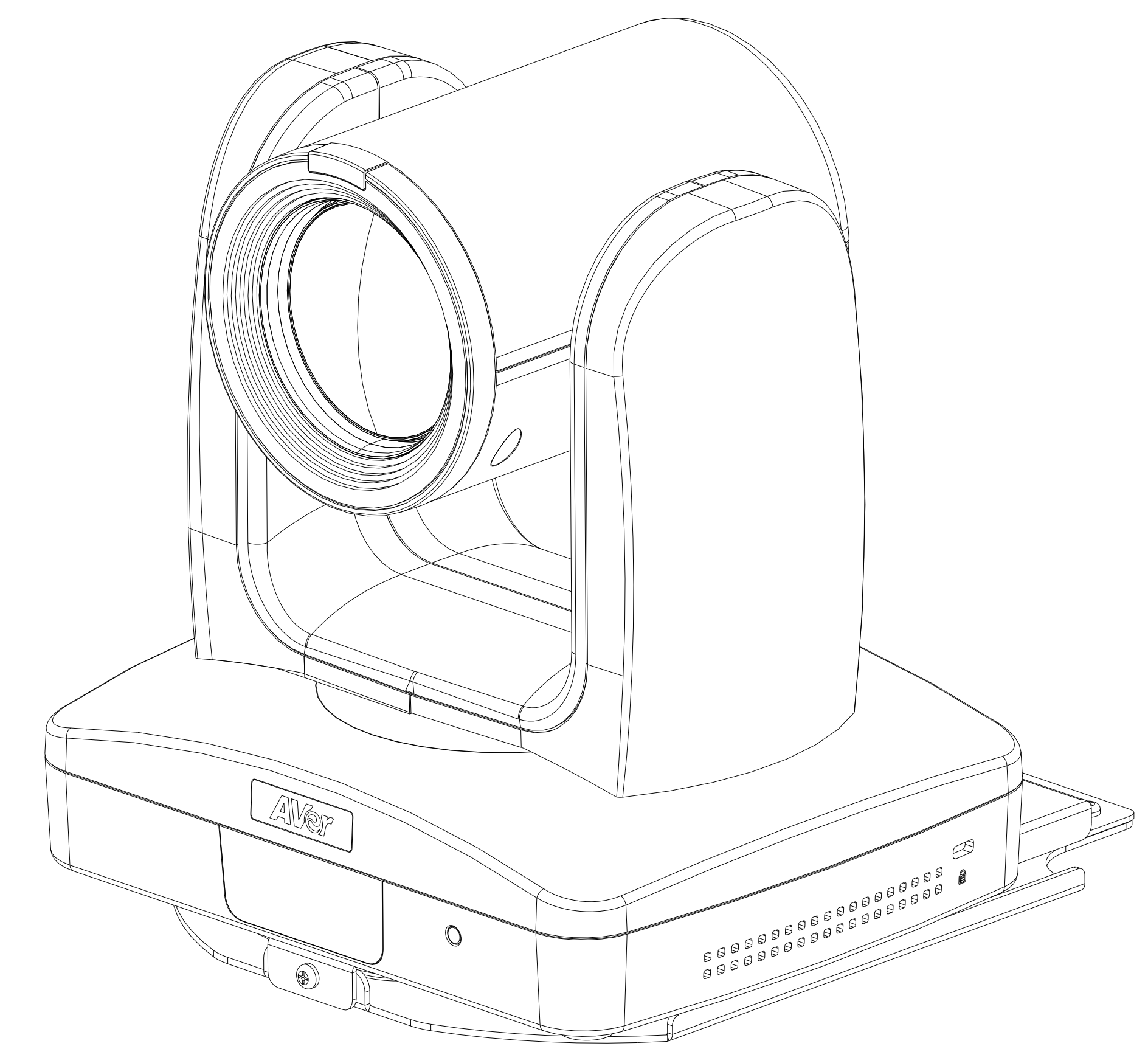
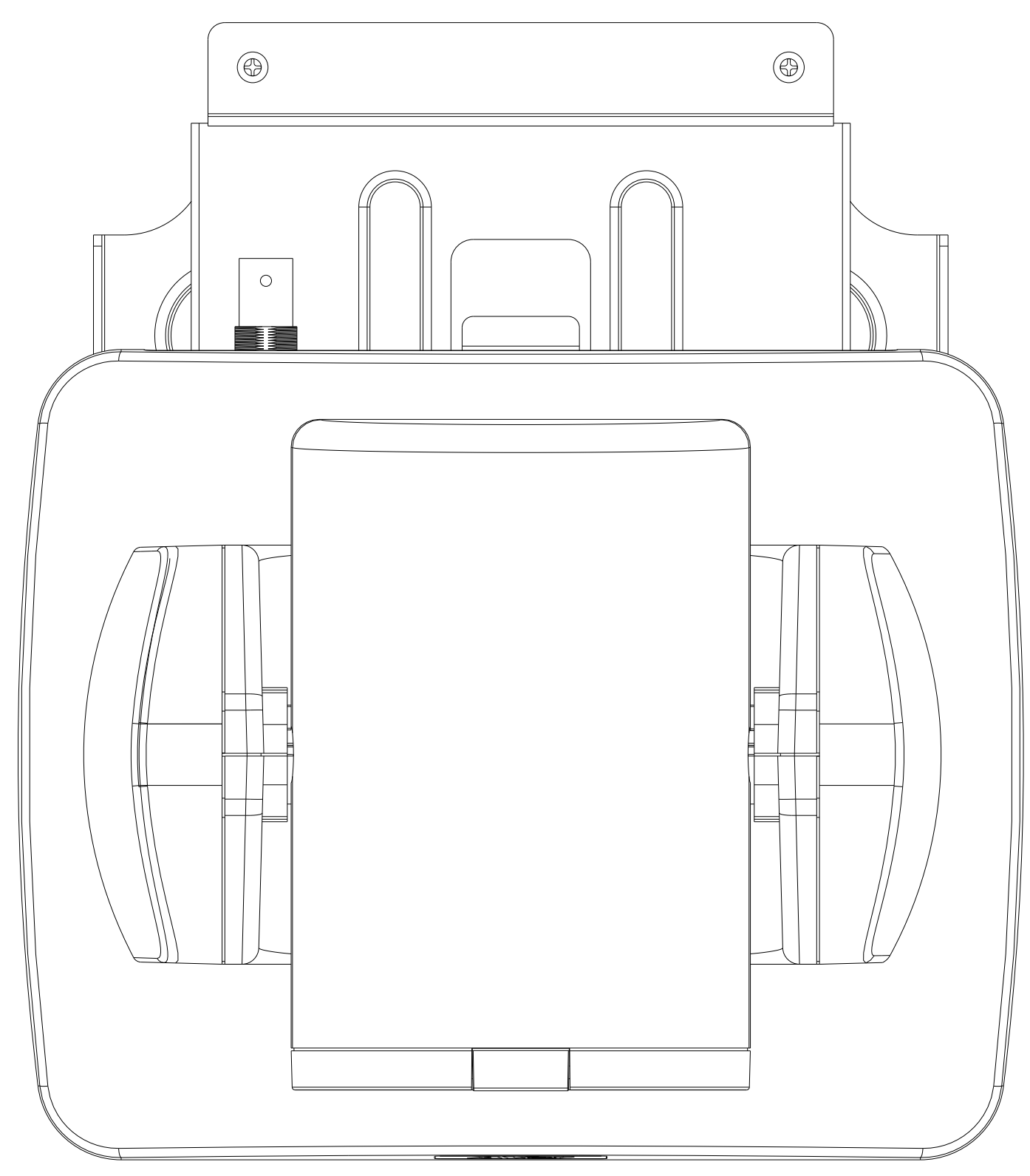

機密 (Confidentiality)

公差表				Unspecified tolerance				單位	mm	材質	機種	S510	品名
TOLERANCE				A class				B class	C class	MAT.	MODEL NAME	DATE	PART NAME
0 -6mm	±0.10mm	±0.05mm	±0.05mm	UNIT	SCALE	VERSION	DATE	CHK.BY	DES.BY	DRA.BY			
>6 -30mm	±0.15mm	±0.10mm	±0.10mm	1:1	V0	2020/04/22	Stanley Hsia	HW CHAO	HW CHAO				
>30 -100mm	±0.20mm	±0.15mm	±0.15mm	SHEET 2 OF 2									
>100 -180mm	±0.25mm	±0.20mm	±0.20mm	Metal Parts Angle ±1°									
>180 -300mm	±0.30mm	±0.25mm	±0.25mm	註：1. 金手指PCB類,未標註之尺寸公差為±0.12mm,其它PCB類及其它機構件未標註之公差如公差表。									
>300 -400mm	±0.50mm	±0.30mm	±0.30mm	NOTE : 1. For PCB with golden finger , unspecified tolerance is ± 0.12mm, other kinds of PCB and mechanical parts , unspecified tolerance see tolerance table.									
Plastic Parts Angle ±0.5°													
Metal Parts Angle ±1°													



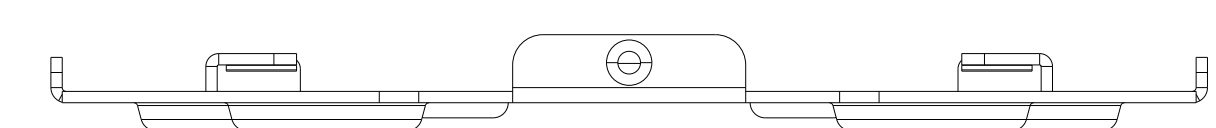
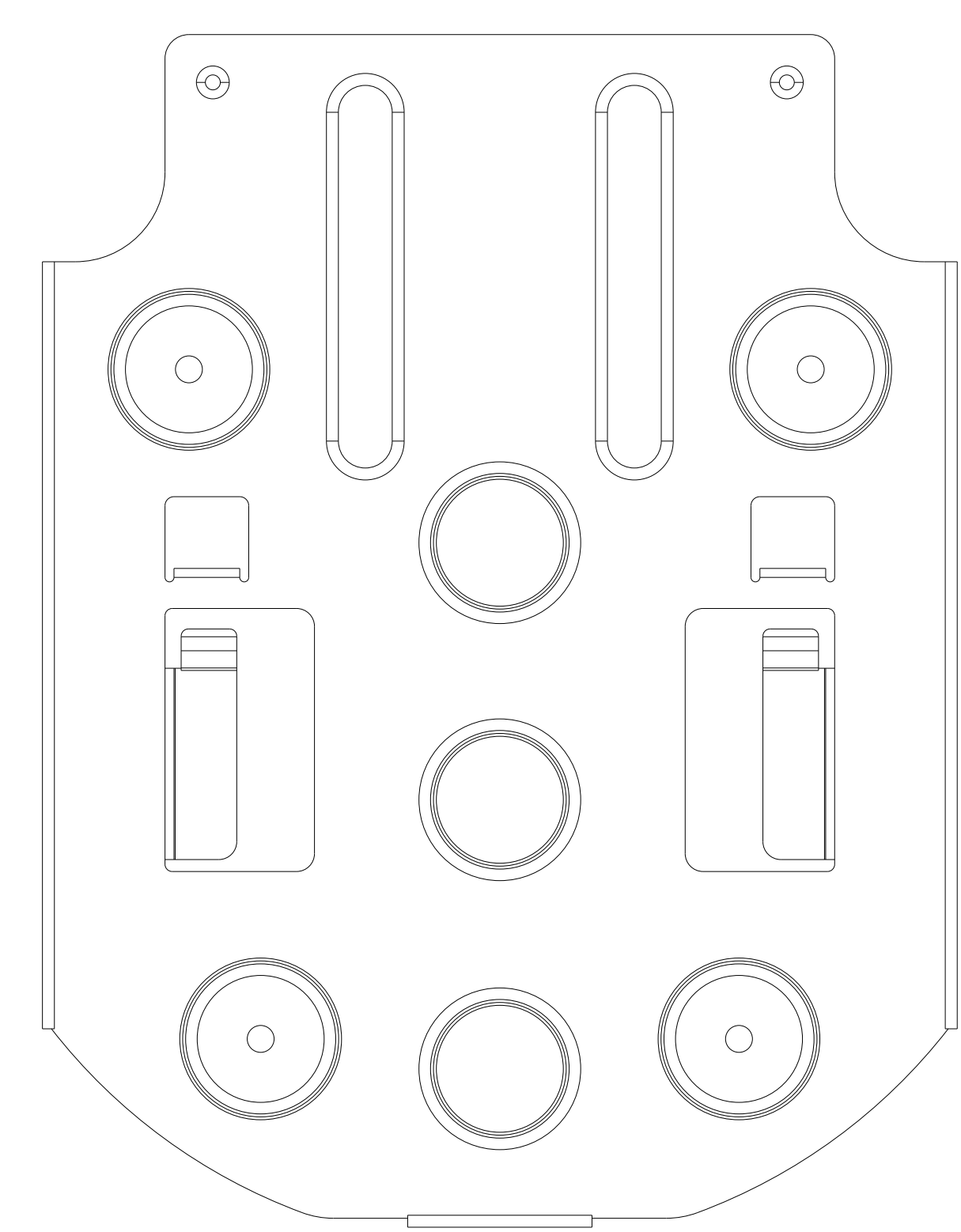
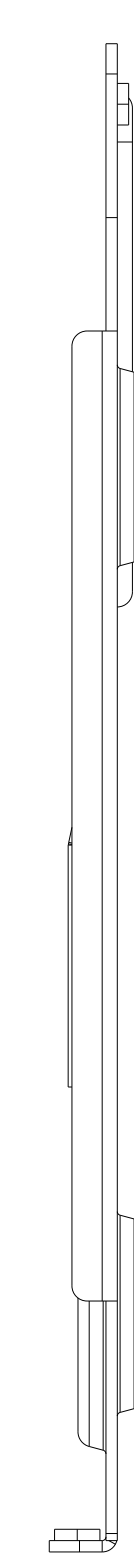
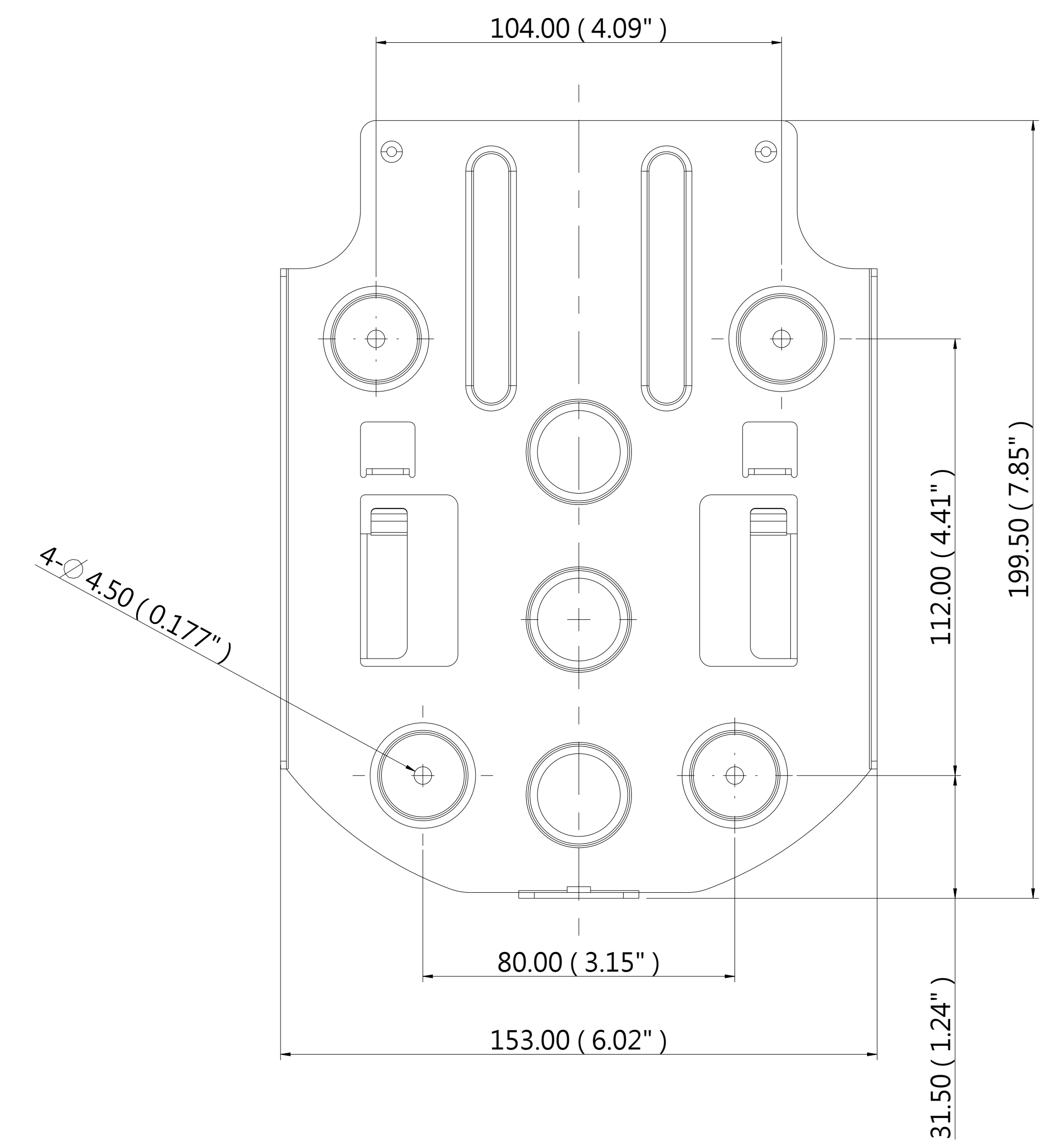
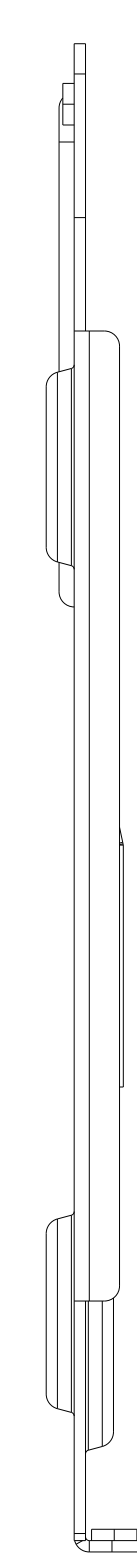
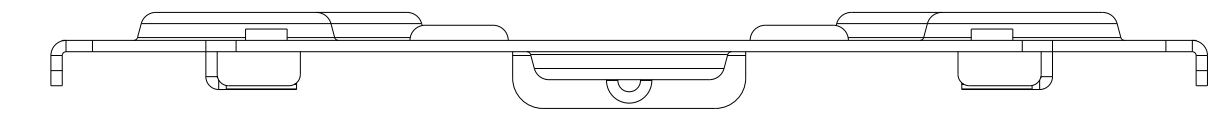
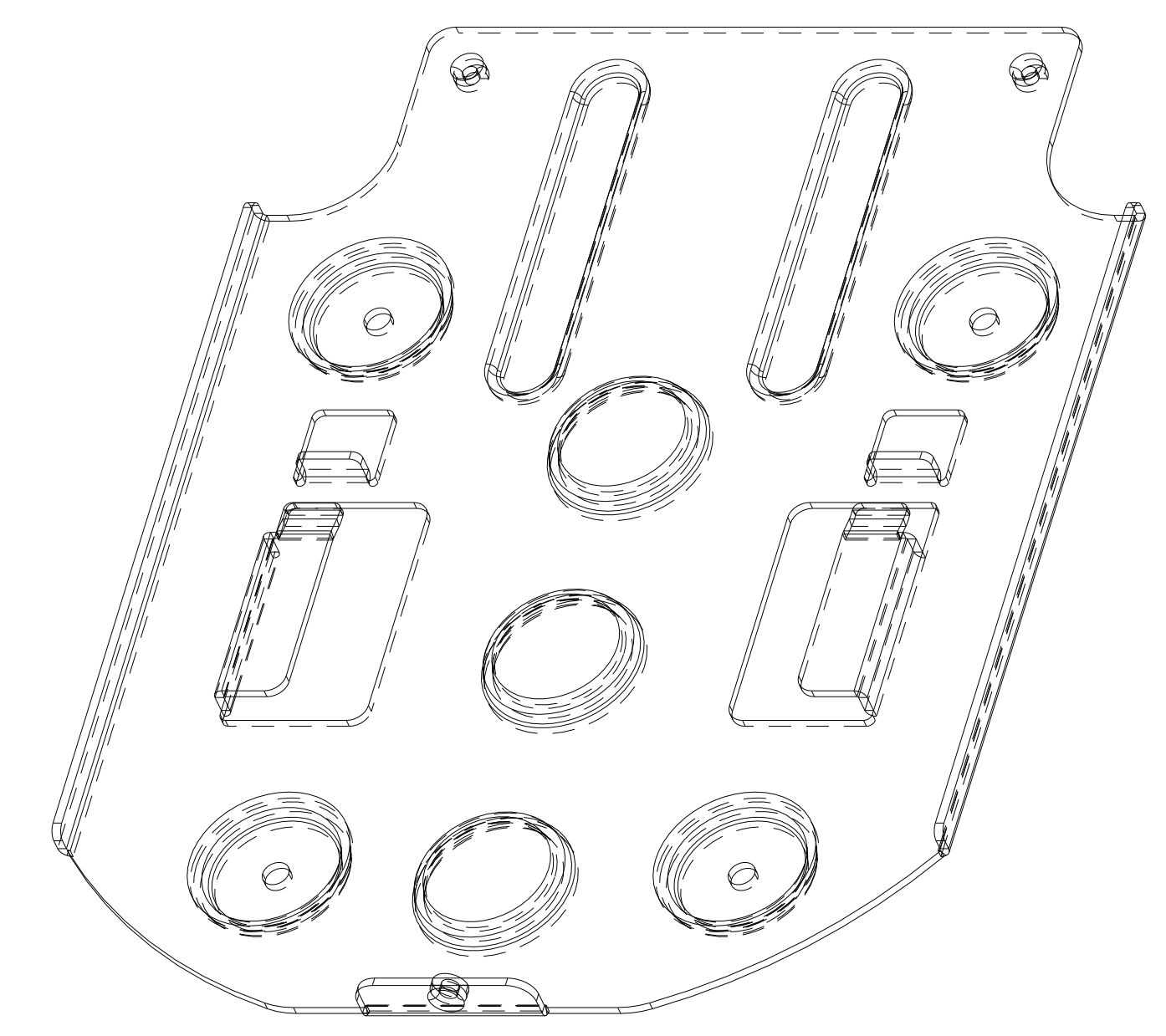

機密 (Confidentiality)

公差表			Unspecified tolerance			單位	mm	材質	PC+ABS SECC FR4 t=1.6mm Rubber	機種	U9P1 U8CO	品名	S990_CEILING-MOUNT
LENGTH	A class	B class	C class	UNIT	MAT.	MODEL NAME	SCALE	VERSION	DATE	CHK.BY	DES.BY	PART NAME	PART NO.
0 -6mm	±0.10mm	±0.05mm	±0.05mm	1:1	V0	2017/03/08				審核	設計	製圖	
>6 -30mm	±0.15mm	±0.10mm								Stanley Hsia	HW CHAO	HW CHAO	
>30 -100mm	±0.20mm	±0.15mm											
>100 -180mm	±0.25mm	±0.20mm											
>180 -300mm	±0.30mm	±0.25mm											
>300 -400mm	±0.50mm	±0.30mm											
Plastic Parts Angle ±0.5°													
Metal Parts Angle ±1°													

註記	日期	內容	簽署
MARKING	DATE	DESCRIPTION	SIGNATURE

註：1. 金手指PCB類,未標註之尺寸公差為±0.12mm,其它PCB類及其它機構件未標註之公差即公差表。
 NOTE : 1. For PCB with golden finger, unspecified tolerance is ±0.12mm, other kinds of PCB and mechanical parts, unspecified tolerance see tolerance table.



Ceiling installation

1. Secure the mount bracket on the ceiling.
Screw: 4 screws, M4 x 10mm(Not Included in the package)

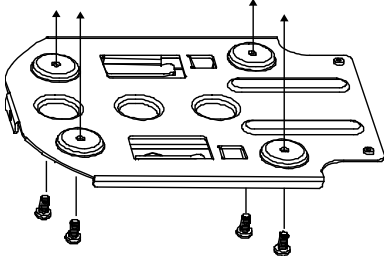

2. Install the mount bracket on the camera.
Screw: 3 screw , 1/4"-20 L=6.5mm(Included in the package)

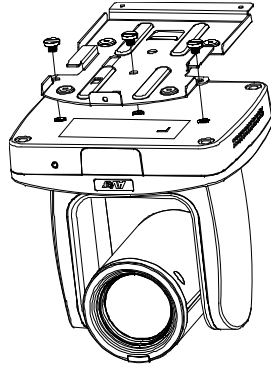

3. Slide the mount bracket with the camera into the mount bracket which secured on the ceiling.

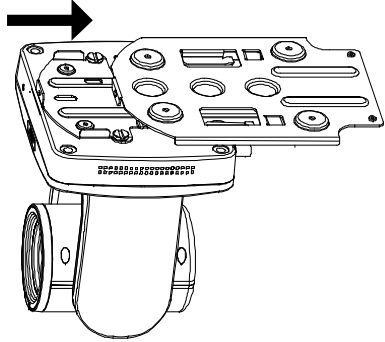

4. Secure the camera with screws.
Screw: 3 screws, M3 x 6mm(Included in the package)

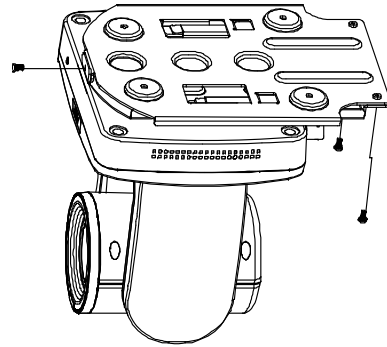

[Note] Connects necessary cables after sliding the camera into the mount bracket.

Dimensions

