

MT300/MT300N

Matrix Tracking Box

— User Manual —

Federal Communication Commission

NOTE: This equipment has been tested and found to comply with the limits for a Class A digital device, pursuant to part 15 of the FCC Rules. These limits are designed to provide reasonable protection against harmful interference when the equipment is operated in a commercial environment. This equipment generates, uses, and can radiate radiofrequency energy and, if not installed and used in accordance with the instruction manual, may cause harmful interference to radio communications. Operation of this equipment in a residential area is likely to cause harmful interference in which case the user will be required to correct the interference at his own expense.

FCC Caution: Any changes or modifications not expressly approved by the party responsible for compliance could void the user's authority to operate this equipment.

This device complies with part 15 of the FCC Rules.

Operation is subject to the following two conditions:

- (1) This device may not cause harmful interference, and
- (2) this device must accept any interference received, including interference that may cause undesired operation.

This Class A digital apparatus complies with Canadian ICES-003. Cet appareil numérique de la classe A est conforme à la norme NMB-003 du Canada.

PSTI Statement of Compliance

Please refer to the following website: <https://www.aver.com/product-security-advisory>

Warning

This is a class A product. In a domestic environment this product may cause radio interference in which case the user may be required to take adequate measures.

Caution

Risk of Explosion if Battery is replaced by an Incorrect Type. Dispose of Used Batteries According to the Instructions.

COPYRIGHT

©2026 AVer Information Inc. All rights reserved. | March 9, 2026

The information contained in this documentation is subject to change without notice.

More Help

For FAQs, technical support, software and user manual download, please visit:

Non-USA

Download Center: <https://www.aver.com/download-center>

Technical Support: <https://www.aver.com/technical-support>

USA

Download Center: <https://www.averusa.com/pro-av/support/>

Technical Support: <https://averusa.force.com/support/s/contactsupport>

Contact Information

Headquarters

AVer Information Inc.
8F, No.157, Da-An Rd.,
Tucheng Dist., New Taipei City
236042, Taiwan
Tel: +886 (2) 2269 8535

USA Branch Office

AVer Information Inc., Americas
44061 Nobel Drive, Fremont, CA
94538, USA
Tel: +1 (408) 263 3828
Toll-free: +1 (877) 528 7824

Europe Branch Office

AVer Information Europe B.V.
Westblaak 134, 3012 KM,
Rotterdam, The Netherlands
Tel: +31 (0) 10 7600 550

Japan Branch Office

アバー・インフォメーション株式会社
〒160-0023 日本東京都新宿区
西新宿 3-2-26 立花新宿ビル 7
階
Tel: +81 (0) 3 5989 0290
お客様サポートセンター(固定電
話のみ): +81 (0) 120 008 382

Vietnam Branch Office

Công ty TNHH AVer Information
(Việt Nam)
Tầng 5, 596 Nguyễn Đình
Chiểu, P.3, Quận 3, Thành phố
Hồ Chí Minh 700000, Việt Nam
Tel: +84 (0) 28 22 539 211
Hỗ trợ kỹ thuật: +84 (0) 90 70
080 77

Korea Office

한국 에버 인포메이션 (주)
서울시 종로구 새문안로 92
(신문로 1가,
광화문오피시아빌딩) 1831,
1832 호
Tel: +82 (0) 2 722 8535

Contents

Overview	1
Compare Modes	1
Understand Human Tracking	2
Package Contents	3
Optional Accessories	3
Parts Info	4
LED Indicators	5
Dimensions	5
Installation	6
Cable Fixing Plate Installation	6
Desk Mount Installation	7
Server Rack Mount (Optional Accessories)	7
Connections	8
RS-422 Connection	9
Get Started	11
Power Your Device	11
Reset Your Device	11
Access the Web Interface	12
AVer Device Utility	12
AVer Enterprise Management	13
Log in for the First Time	13
User Interface	14
Add, Edit or Delete Devices	15
Live Mode	17
Manual Mode	19

Auto Mode (Channel)	21
Add, Edit or Delete Groups.....	25
Device Status	26
Assign a Priority Group	26
Understand Active Channels	27
Configure Multiple Speakers Mode	28
Configure Output Layout	30
Customize your video layout with a Single view, Side-by-side view, Active Speaker view, Picture-in-Picture view, and Customized view.	30
Output Layouts	30
How to Hide Inactive Grids.....	32
Auto Mode (Active Position)	33
Supported Devices	33
Square Microphone Calibration.....	34
Round Microphone Calibration.....	36
Add a Coverage Area	39
System Settings	40
Video & Audio	40
Network.....	42
NDI.....	45
System.....	47
Help	49
MT Control Panel App	50
Install MT Control Panel	50
Pair with MT Control Panel.....	50
Add and Switch between Matrix Boxes	51

Specifications	53
Troubleshoot	54
Appendix	55
Supported AVer Devices	55
Supported Microphones	57
Audio-Technica	57
Biamp	61
Bosch	66
ClearOne	70
Nureva	73
Sennheiser	76
Shure	80
Yamaha	87
HTTP Requests	88
AVer Control Panel (formerly PTZ Control Panel)	91
TCP Commands	94
VISCA Command Table	94

Overview

The MT300 is a multi-camera matrix box with integrated voice-tracking technology. Three built-in modes—Live Mode, Manual Mode, and Auto Mode— help you present video feeds in a single, composited stream, while supported AVer cameras automatically switch views based on the active speaker's position.

Compare Modes

- **Live Mode:** Preview live video and control PTZ. Settings are not saved, making it suitable for on-the-fly operation.
- **Manual Mode:** Save fixed camera presets and output layouts. Supports human tracking.
- **Auto Mode:** Uses two types of voice-tracking technology—based on microphone channels or coordinate-based positioning—to automatically frame the active speaker.

Feature	Live Mode	Manual Mode	Auto Mode - Channel	Auto Mode - Active Position
Live view camera count	4	4	4	–
Profiles	–	36	36	36
Presets	–	256	256	–
AVer camera + microphone groups	–	–	25	–
Human Tracking	–	✓	✓	–
3 rd -party microphone integration	–	–	✓	✓
X, Y, Z coordinates input	–	–	–	✓

Understand Human Tracking

Human Tracking includes Presenter, Zone, Segment (supported models), and Hybrid Modes.

To enable human tracking with Manual Mode and Auto Mode (Channel), make sure you have configured required tracking modes on the camera web interface. Please refer to [<Supported AVer Devices>](#) for supported AVer devices and your camera's user manual for tracking mode settings.

Example: Auto Mode (Channel) with Presenter Mode



Channel 1 detects voice



Camera moves to preset 1



Presenter Mode is turned on

Package Contents



Matrix Tracking Box

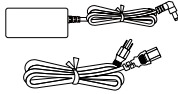

Power Adapter &
Power Cord

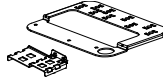

Cable Fixing Plate
(x2)

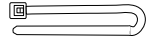

Cable Ties (x13)



3.0 x 5mm
Flat Head Screw (x5)



3.0 x 5mm
Truss Head Screw
(x4)

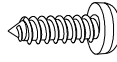

M3 x 10mm
Screws (x4)

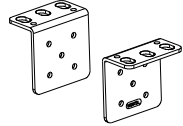

Rack Mount Bracket
(x2)

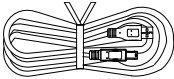

USB 3.0 Cable (x2)
1.5 m/4.92 ft



RS-422 Cable



Quick Start Guide



Warranty Card
(Japan only)

Optional Accessories

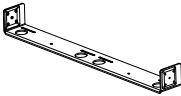

Server Rack Mount



3.0 x 5mm
Flat Head Screw (x3)



3.0 x 5mm
Truss Head Screw (x2)

Parts Info

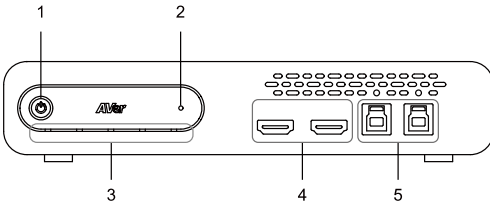

Front View

1. Power Button
2. Reset Button
3. LED Indicators
4. HDMI Out Port (x2)
5. USB Out 3.0 Type-B Port (x2)
(single USB out port per use only)

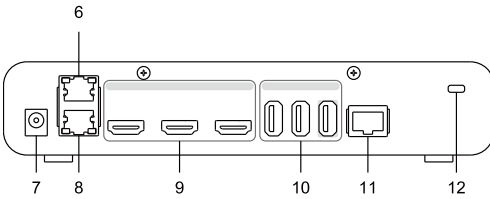

Back View

6. PoE+ Port IEEE 802.3AT
7. DC Power Jack
8. Ethernet Port
9. HDMI In Port (x3)
10. USB In 2.0 Type-A Port (x3)
11. RS-422 Port
12. Kensington Lock

LED Indicators

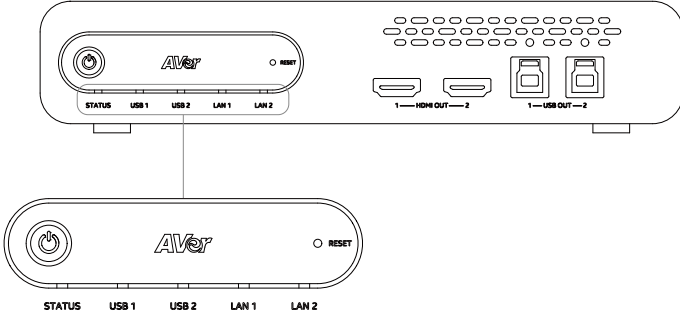

STATUS

Color	Status
Solid orange	Standby
Solid green	Normal
Flashing green	Firmware upgrade

USB 1, USB 2

Color	Status
Solid green	Connected
Flashing green	Streaming

LAN 1, LAN 2

Color	Status
Solid green	Connected

Dimensions

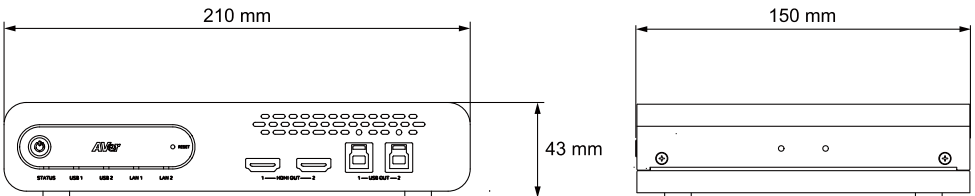

Installation

Cable Fixing Plate Installation

1. Secure the cable fixing plates to the tracking box with 5 flat hat 3.0 x 5 mm screws in the package.

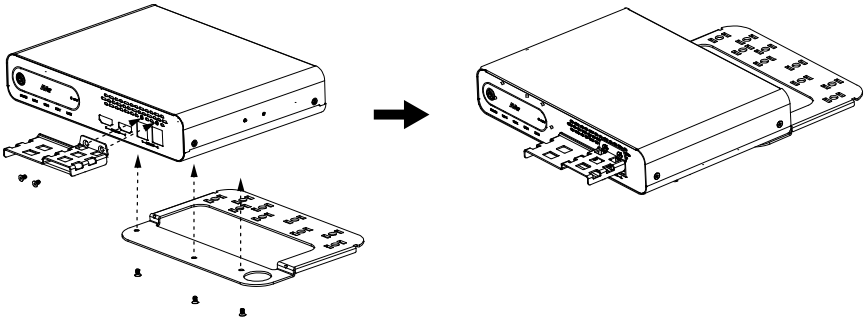

2. Plug in cables.

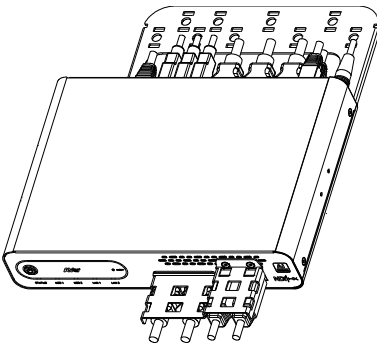

3. Use 13 cable ties in the package to secure the cables and cable fixing plates.

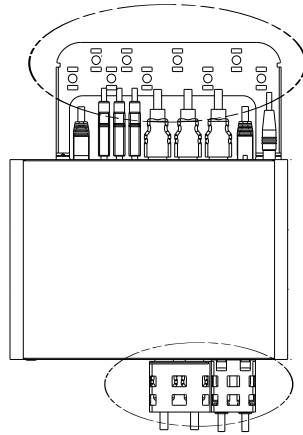

Desk Mount Installation

1. Secure the mount brackets on the tracking box.
Screw: 4 truss head screws, 3.0 x 5 mm

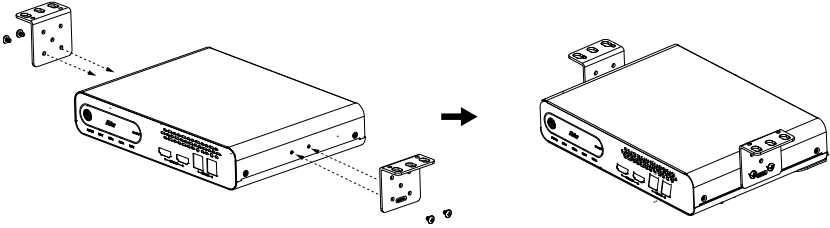

2. Install the mount brackets and the tracking box under the desk.
Screw: 4 screws, M3 x 10 mm

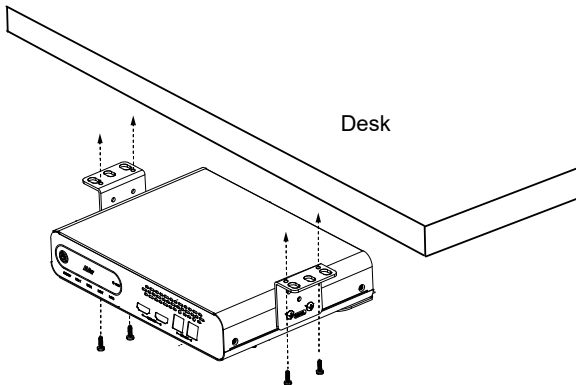

Server Rack Mount (Optional Accessories)

For details on optional accessories, consult your local dealer.

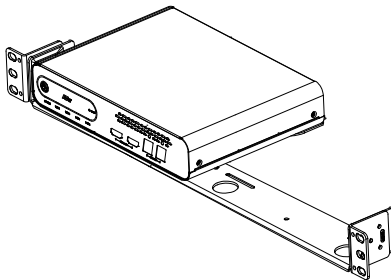

Connections

- **Front Panel**

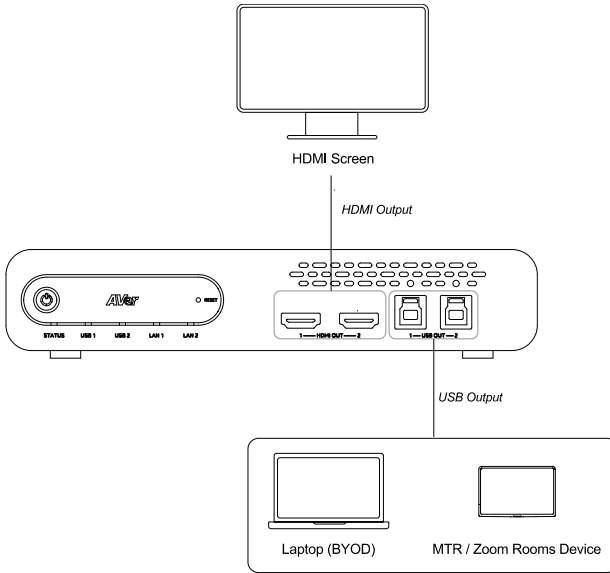

- **Back Panel**

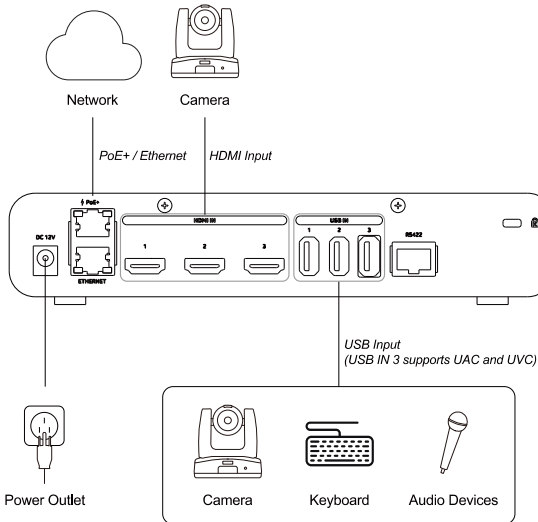

RS-422 Connection

Use an RS-422 adapter cable to make a RS-422 connection to your control device.

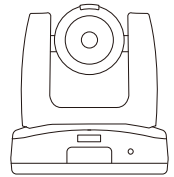
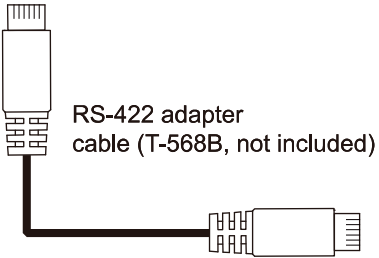
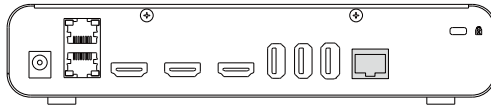
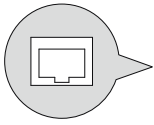

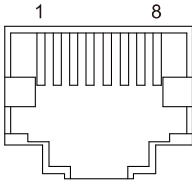

Pin #	Pin
1	TX+
2	TX-
3	RX+
4	TX+
5	TX-
6	RX-
7	RX+
8	RX-

RS-422 Port Pin Definition

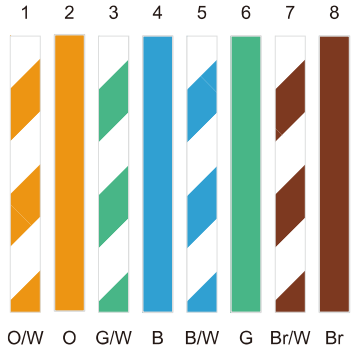

T-568B Cable

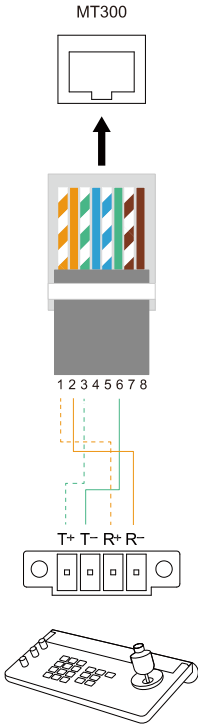

Get Started

Power Your Device

The device automatically powers on when connected to power. No need to press the **power** button . Press and hold for 5 seconds to enter Standby Mode. Press once to wake up.

Reset Your Device

Insert a paper clip into the reset hole, push in and hold for 5 seconds to reset to the device to factory default settings.

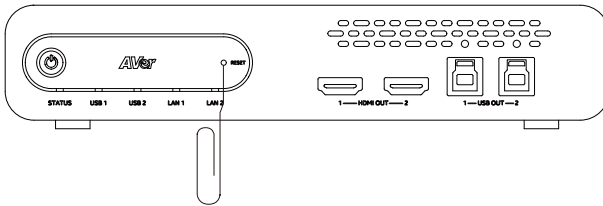

Access the Web Interface

To access the web interface of the Matrix Tracking Box, you can use any of the following software to find its IP address:

- AVer Device Utility
- AVer Enterprise Management

Note:

- The default network setting is as follows:
PoE+ port: DHCP
Ethernet port: Static IP 192.168.168.168
- The default username and password is **admin/admin**.

AVer Device Utility

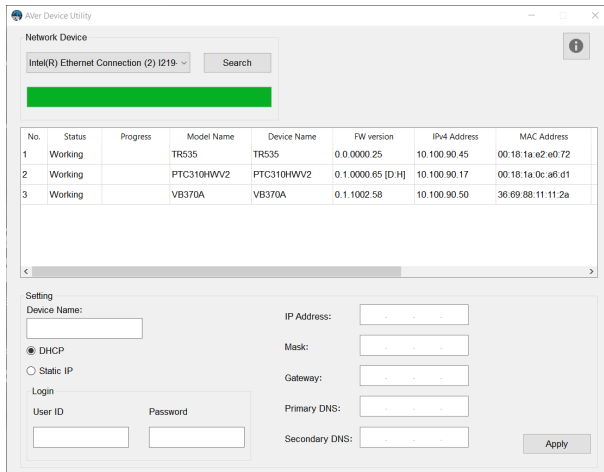

To access the web interface:

1. Download AVer Device Utility from AVer Download Center (<https://www.aver.com/download-center>) and launch the software.
2. Click **Search** to see available devices on the same local area network (LAN).

Note:

- Make sure your device is connected to the internet.
 - AVer Device Utility and your device must be on the same LAN.
3. Double-click on your device's IP address in the **IPv4 Address** column to open the web interface in your browser.

To change your network to DHCP or static IP:

1. Select the checkbox of your device.
2. Enter the username and password in the **Login** field.
3. Select **DHCP** or **Static IP**, then enter your network settings if applicable in the **Settings** section.
4. Click **Apply**.

AVer Enterprise Management

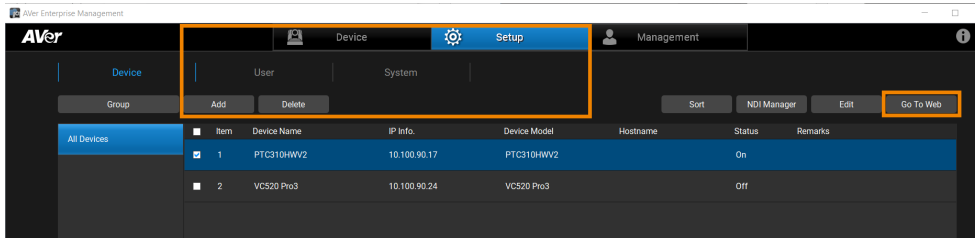

Note: AVer Enterprise Management default username and password is **admin/admin**.

To access the web interface:

1. Download AVer Enterprise Management from AVer Download Center (<https://www.aver.com/download-center>) and launch the software.
2. Log in with the default username and password **admin/admin**.
3. Go to **Setup > Add**, then click **Auto Search** to see available devices on the same local area network (LAN).
4. Click to select your device, enter the username and password, then click **Save** to add the device to the device list.
5. Select the checkbox of your device, then click **Go to Web** button to open the web interface in your browser.

Log in for the First Time

When you log in for the first time, you'll be prompted to change the username and password. The username and password cannot be the same.

- Username: Use 1-32 characters.
- Password: Use 8-32 characters and a combination of uppercase letters, lowercase letters, and numbers. Symbols (!\$%'()*+,-./<=>?@[^_{}~) are optional.

User Interface

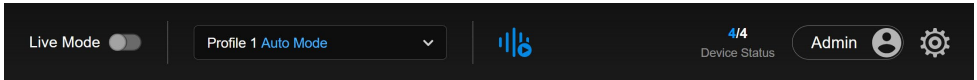

From left to right:

1. Live Mode Toggle

2. Profile Menu

A single profile can store both Manual Mode and Auto Mode settings, but only one mode can be active at a time. To switch modes, go to **Settings**  > **Profile**.

Note: When using non-AVer cameras, only Live Mode and Manual Mode are supported. Auto Mode (voice tracking) and camera control are not available.

3. Pause / Resume Voice Tracking

4. Device Status

Shows the number of online devices / total added devices.

5. Account

Switch between Admin and User roles.

Users can operate voice tracking but cannot modify settings.

6. Settings

Add devices, configure voice tracking, and manage system settings.

Add, Edit or Delete Devices

You can add up to 25 unique cameras and 25 unique microphones via USB, HDMI and IP.

Note: You can create up to 25 groups, but Auto Mode (Channel and Active Position) supports a maximum of 7 unique cameras. Multiple groups can share the same camera.

Camera connection limits:

- IP and/or USB cameras: up to 4
- HDMI cameras: up to 3

To add devices:

1. Access the web interface.
2. Go to **Settings**  > **Device** > **Add device**.

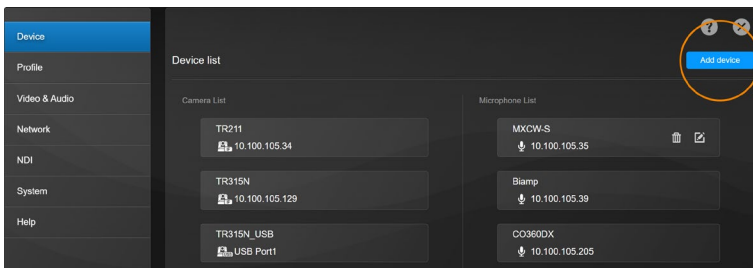

3. Fill out the **Add New Device** dialog box:

- Camera

Item	Description
Select Camera or Microphone	Select camera.
Connect Camera via	Select the camera's connection method. <ul style="list-style-type: none">● USB 3 streams both audio and video, while USB 1 and 2 stream video only.● HDMI cameras must also be connected via IP to enable PTZ control (IP, RS-422) and human tracking (IP).● Non-AVer camera via IP supports only Live Mode and Manual Mode. Auto Mode (voice tracking) and PTZ control are not supported.
IP Address	Click Auto Search or enter the IP address.
Camera Account	Enter the camera's username and password.
Camera Password	



Streaming via RTSP	<ul style="list-style-type: none"> Real-Time Streaming Protocol (RTSP): Ensure both the camera and the receiving device/application support RTSP. Enter the camera's RTSP username and password, if any. Network Device Interface (NDI): Ensure both the camera and the receiving device/application support NDI. You can optionally assign an NDI group name.
Streaming via NDI	
Device Name	Enter the name you want to display in the device list.

- Microphone

Item	Description
Select Camera or Microphone	Select microphone.
Microphone Brand	Select microphone brand.
IP Address	Enter the IP address.
Device Name	Enter the name you want to display in the device list.

4. Click **Save**.

To edit or delete devices:

1. Hover over the device.
2. Click the **Pencil** icon  to edit it. Or click the **Trash can** icon  to delete it.

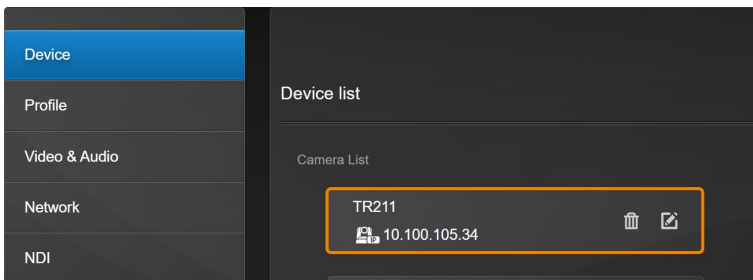

Live Mode

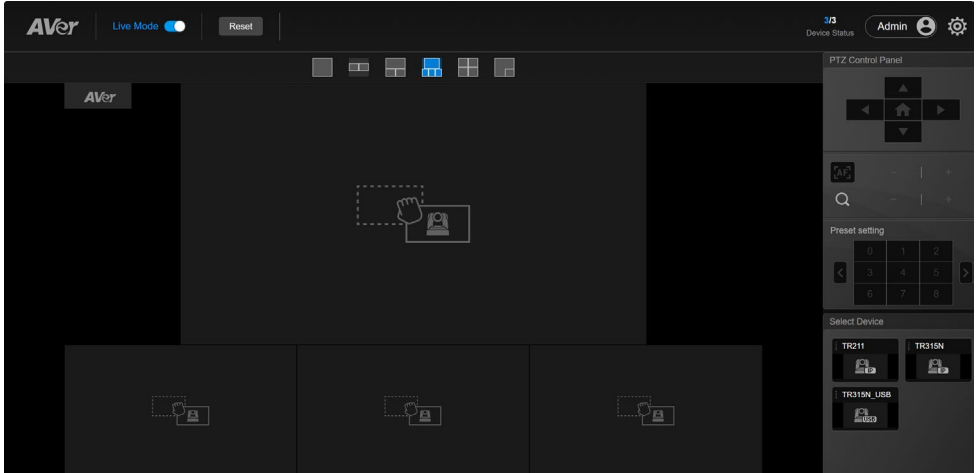

Live Mode lets you preview live video, control PTZ, adjust the video layout, and select audio sources. Settings are not saved, making this mode ideal for temporary or on-the-fly operation.

To set up:

1. Toggle on **Live Mode**.
2. Select an output layout.



3. Drag a camera icon from Select Camera onto the grid. The blue number on each camera icon indicates its position in the layout.

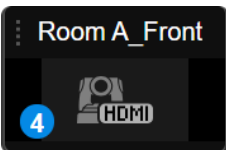

4. To clear the settings, click **Reset**.

To control a camera:

1. Click a grid to select a camera. The selected camera is highlighted with a blue frame, and the PTZ control panel becomes active.
2. Do any of the following:
 - PTZ control
 - Switch between PTZ and wide-angle lenses (TR535/TR535N only): Click the **switch lens** button .
 - Load a preset: Click its preset number.

Manual Mode

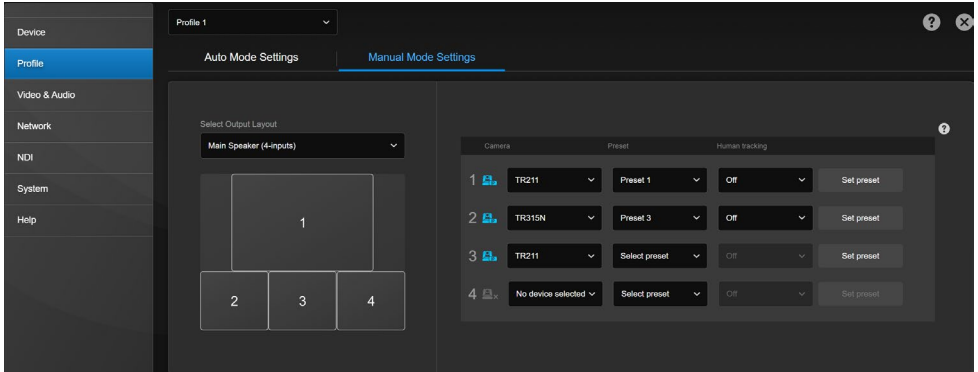

Manual Mode allows you to save fixed camera presets and output layouts for the room, and use human tracking to frame the speaker. Before using Manual Mode, make sure the required tracking mode is configured in each camera's web interface.

To set up:

1. Go to **Settings**  > **Profile** > **Manual Mode Settings**.
2. From the Profile drop-down menu, select the profile you want to save. To rename a profile, select the profile and click **Rename**.

Profile 1 

Note: A single profile can store both Manual Mode and Auto Mode settings, but only one mode can be active at a time.

3. Select an output layout, then choose the camera, preset, and human tracking mode.
To add a preset, click **Save preset** > use PTZ control to move the camera > click a preset number > click **Save** > click **Back** to return to the profile page.

4. Click  to exit the profile page. Your settings are automatically saved and applied. You can confirm the active mode from the profile drop-down list on the home screen.

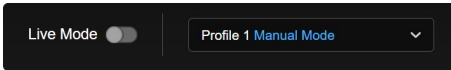

Auto Mode (Channel)

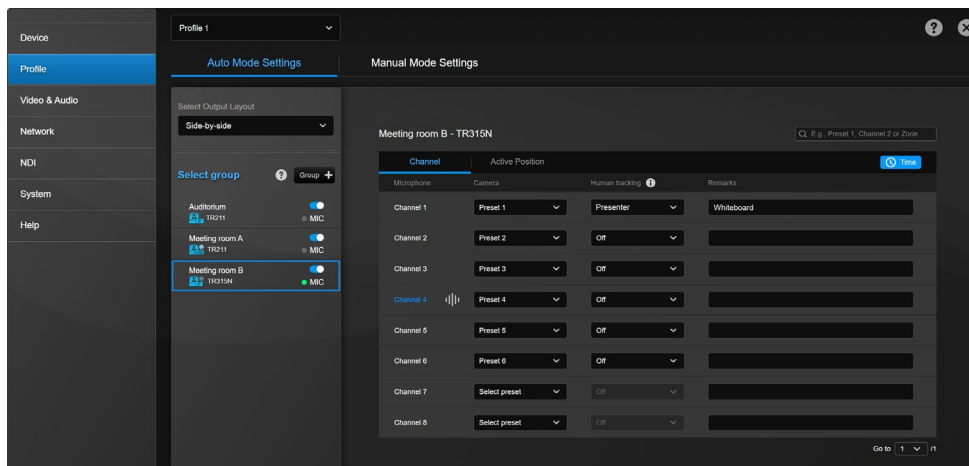

Auto Mode (Channel) integrates supported third-party microphone systems from Audio-Technica, Biamp, Bosch, ClearOne, Nureva, Sennheiser, Shure, and Yamaha. By pairing AVer camera presets with microphone channels, the system uses voice tracking to automatically frame the active speaker.

Note: Third-party microphones may require configuration in their manufacture software. For microphone settings, please refer to <[Supported Microphones](#)>.

To set up:

1. Go to **Settings** > **Profile** > **Auto Mode Settings**.
2. From the Profile drop-down menu, select the profile you want to save. To rename a profile, select the profile and click **Rename**.

Profile 1

Note: A single profile can store both Manual Mode and Auto Mode settings, but only one mode can be active at a time.

3. Select an output layout, then create groups by pairing the cameras you want with microphones and selecting the number of microphone channels.

Note: You can create up to 25 groups, but Auto Mode (Channel and Active Position) supports a maximum of 7 unique cameras. Multiple groups can share the same camera.

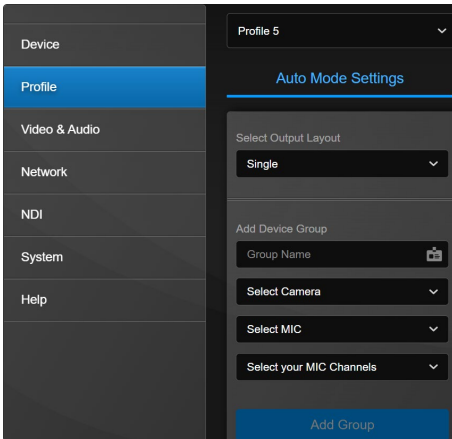

4. Newly created groups appear under **Select Group**. Click **Group +** to add additional groups.

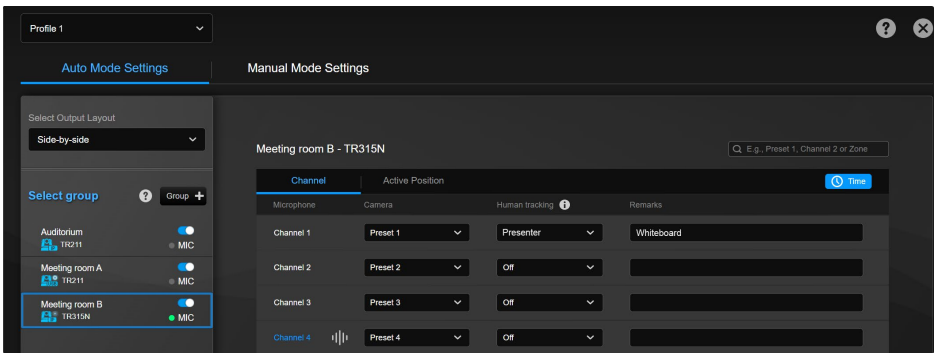

5. Create presets and pair them with microphone channels.

Use the camera remote or click the group's hamburger menu  > **Set preset** to create presets according to the seating arrangement. Then pair each preset with the appropriate microphone channel.

6. If you are using Shure MXA920 microphones, configure lobes or coverage areas in the Shure software. Refer to [<Supported Microphones>](#) for instructions.
7. (Optional) Click  to set a delay before the camera moves to a preset.

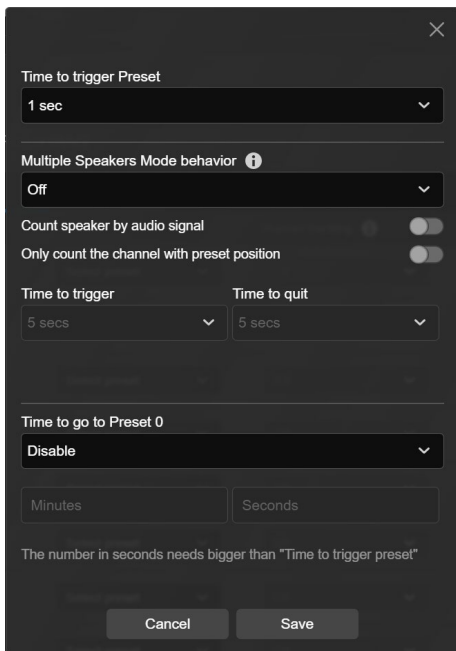

Item	Description
Time to trigger Preset	The group's camera moves to a preset after the delay time you set.
Multiple Speakers Mode behavior	When the microphone picks up multiple people speaking at the same time, the group's camera moves to preset 0. The purpose of this feature is to frame the whole room instead of switching rapidly between individual speakers. Refer to <Configure Multiple Speakers Mode> .
Time to go to Preset 0	When the microphone picks up no sound, the group's camera moves to preset 0 after the delay time you set. You can optionally choose a different preset other than preset 0 by assigning a priority group . Note: The duration of Time to go to Preset 0 must be longer than Time to trigger Preset .
Far end speakers trigger Preset 0 (Sennheiser TCC2/TCCM,	When the microphone picks up audio from far-end participants on a video conferencing software, the group's camera moves to preset 0. This purpose of this feature is to show the whole room

Shure P300 only)

and prevent false tracking. You can optionally choose a different preset other than preset 0 by [assigning a priority group](#).

8. Click  to exit the profile page. Your settings are automatically saved and applied. You can confirm the active mode from the profile drop-down list on the home screen.

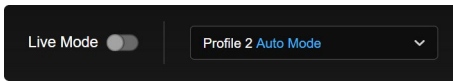

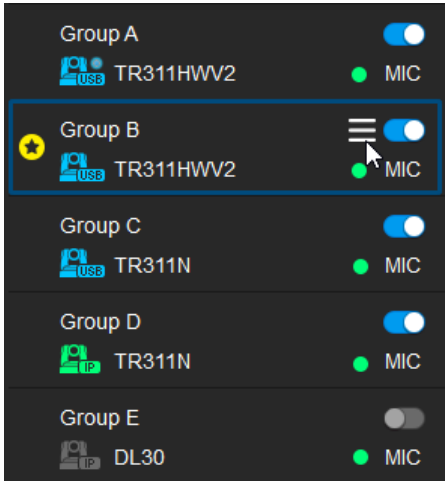

Add, Edit or Delete Groups



To add groups:





1. Access the web interface.
2. Go to **Settings**  > **Profile** > **Auto Mode Settings** > Click **Group +**.

To edit or delete groups:



1. Hover over a group.
2. Click the hamburger menu , and do any of the following:
 - Set preset: Add camera presets.
 - Edit group
 - Delete group
 - Group overlay priority: Assign a priority group .
3. (Optional) Toggle a group on or off to enable or disable a group.

Device Status

- Camera

Color	Status
	Camera is sending data to MT300
	Device online
	Device offline
	Incorrect account or password

- Microphone

Color	Status
 Green	Online
 Gray	Offline

Assign a Priority Group

You can assign a priority group for the camera to go to when:

- Multiple groups share a camera.
- Microphone detects no sound (default preset 0).
- Multiple Speakers Mode activates (default preset 0).
- Microphone detects far end speakers (Sennheiser, Shure P300 + MXA920 microphones only, default preset 0)



To assign:

1. Hover over a group, then click the hamburger menu .
2. Click **Group overlay priority**.

A **star** icon  will appear next to the priority group.

3. Click **Group overlay priority** again to cancel priority group.

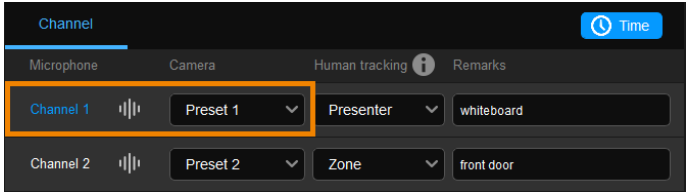
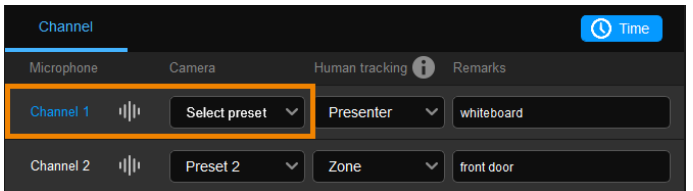
Understand Active Channels

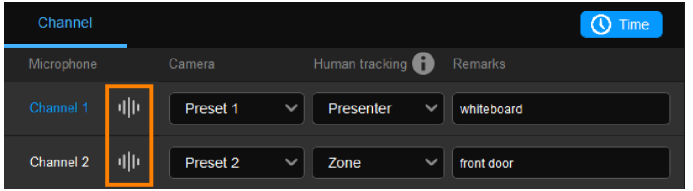
Channel Type	Example
<p>Active channel (blue highlight) + a preset</p> <p>An active channel indicates the camera's location.</p>	 <p>The screenshot shows a 'Channel' interface with a 'Time' button in the top right. Below the title are tabs for 'Microphone', 'Camera', 'Human tracking', and 'Remarks'. Two channels are listed: 'Channel 1' and 'Channel 2'. 'Channel 1' is highlighted in blue and has an audio signal icon and a 'Preset 1' dropdown menu. 'Channel 2' has an audio signal icon and a 'Preset 2' dropdown menu. The 'Preset 1' dropdown is highlighted with an orange box.</p>
<p>Active channel (blue highlight) (no preset)</p> <p>An active channel can be without a preset.</p>	 <p>The screenshot shows the same 'Channel' interface. 'Channel 1' is highlighted in blue and has an audio signal icon, but the dropdown menu is labeled 'Select preset'. 'Channel 2' has an audio signal icon and a 'Preset 2' dropdown menu. The 'Select preset' dropdown is highlighted with an orange box.</p>
<p>Audio signal icon </p> <p>An audio signal icon channel indicates that the channel detects sound.</p>	 <p>The screenshot shows the same 'Channel' interface. Both 'Channel 1' and 'Channel 2' have audio signal icons. The audio signal icon for 'Channel 1' is highlighted with an orange box.</p>

Configure Multiple Speakers Mode

When the microphone picks up multiple people speaking at the same time, the group's camera moves to preset 0. The purpose of this feature is to frame the whole room instead of switching rapidly between individual speakers.

To set up:

1. Go to **Settings**  > **Profile** > **Auto Mode Settings** > select a group > click .
2. Enable the mode by selecting **Back to Preset 0**.

You can optionally choose a different preset other than preset 0 by [assigning a priority group](#).

3. Set **Time to trigger** and **Time to quit** to enter and exit the mode.

Important: Set both **Time to trigger** and **Time to quit** to 3X the **Time to trigger preset**, so the system has enough time to detect multiple simultaneous speakers.

4. Depending on your microphone type, toggle filters to adjust how speakers are detected:

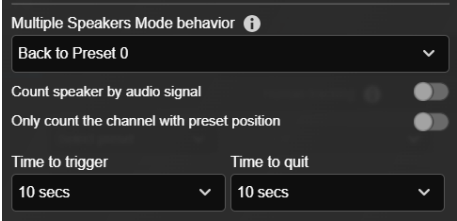
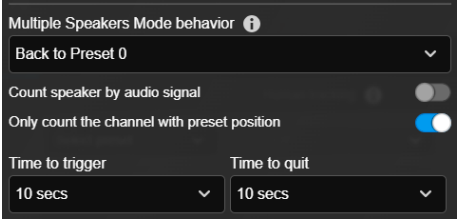
Type	Filter	Trigger Behavior
Ceiling microphone	Both toggles off 	Detecting sound from 3 different active channels within the selected Time to trigger . <i>(Active channels with or without presets.)</i>
	Toggle on Only count the channel with preset positions 	Detecting sound from 3 different active channels with presets within the selected Time to trigger .

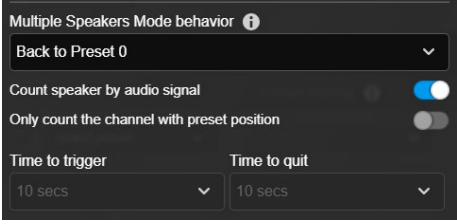
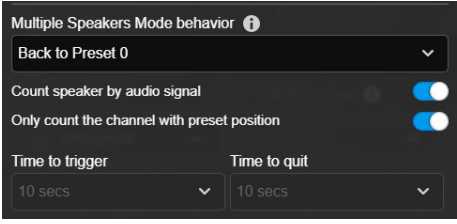
<p>Gooseneck microphone</p>	<p>Toggle on Count speaker by audio signal</p> 	<p>Detecting 2 or more audio signal at the same time.</p> <p><i>(Active channels with or without presets.)</i></p>
	<p>Both toggles on</p> 	<p>Detecting 2 or more audio signal with presets at the same time.</p>

Configure Output Layout

Customize your video layout with a Single view, Side-by-side view, Active Speaker view, Picture-in-Picture view, and Customized view. The default setting dynamically adds up to 4 channels and keeps a fixed grid layout, but you can also enable [Layout Reduction](#) to hide inactive channels.

Output Layouts

To select an output layout, go to **Settings** ⚙️ > **Profile** > **Auto Mode Settings** > select a group >

Select Output Layout.

- **Single**

Displays current active channel's camera view in full-screen.

When all channels are muted, it shows the camera view of the first group on the list.

When one channel is muted, the next active channel will take over the full-screen.

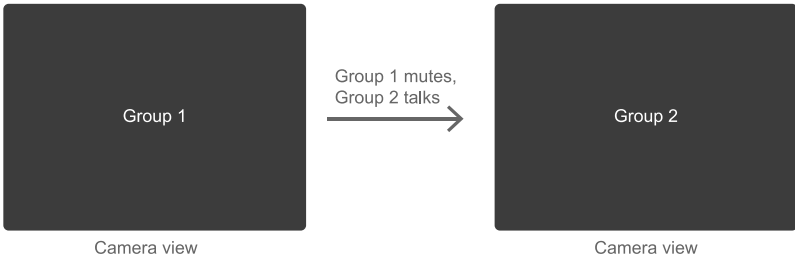

- **Side-by-side**

Displays the camera views of two active channels side by side.

When one channel is muted, the next active channel takes the first available grid.



- **Active Speaker**

Dynamically displays the current active channel in the top large grid, while up to three standby channels appear in smaller grids on the second row.

When one channel is muted, the next active channel takes the first available grid.

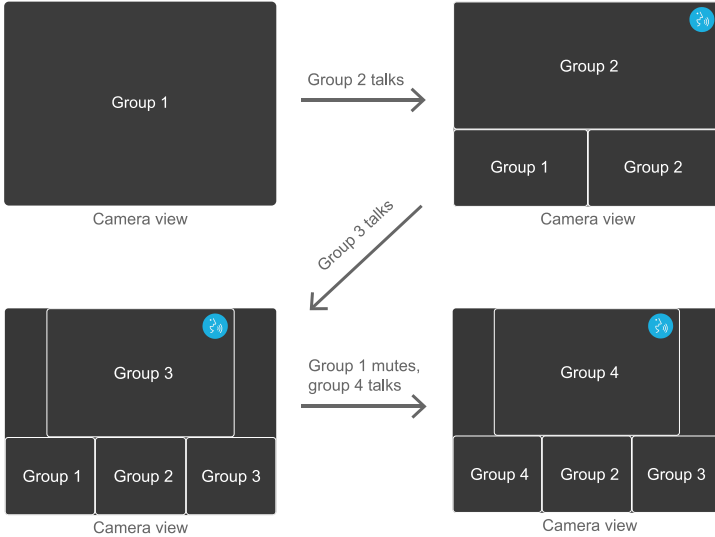

- **Picture-in-Picture (PIP)**

Displays two active channels in full-screen with a smaller grid.

When one channel is muted, the next active channel takes the first available grid.

Note: When all channels are muted, it shows the camera view of the first group on the list, sorted alphabetically. To change the order, rename the group accordingly.

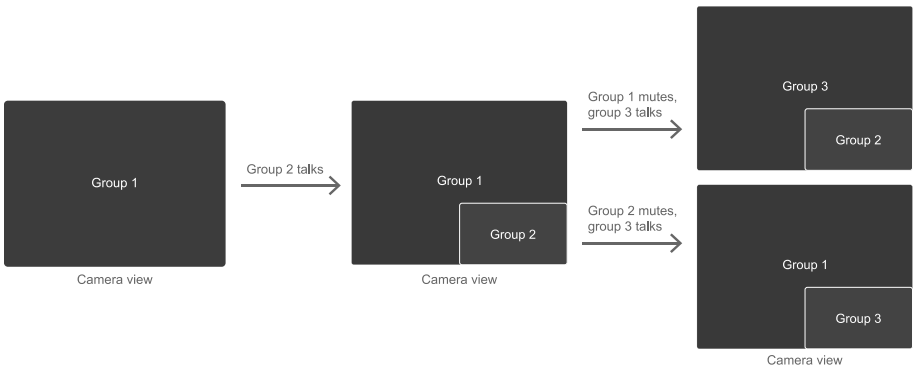

- **Customized** (priority group unavailable)

1. Select a customized layout from the pop-up window, or click  next to Customized.

For a layout without blank space, we recommend using **4-inputs (1T-F+3B)**.

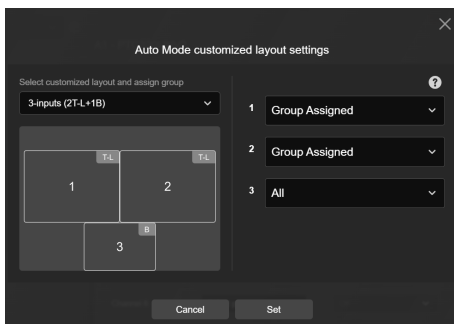

- T = Top
- L = Large
- B = Bottom
- F = Full screen (no blank space)

2. Assign one, multiple, or all groups to each grid using the drop-down lists.

- Newly assigned grids display “Group Assigned” or “All.” Displaying group names are unavailable at this time.
- When a channel is muted, the next active channel takes its assigned grid.

3. When finished, click **Set**.

4. To edit a customized layout and re-assign groups, click  next to Customized.

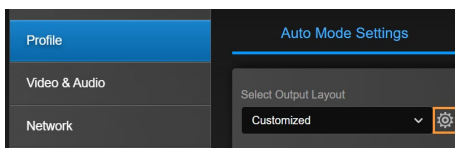

5. (Optional) To disable human tracking for a specific grid, go to **Profile > Auto Mode Settings >** select the grid's group > set every channel's human tracking to **Off**.

How to Hide Inactive Grids

Hiding inactive channels can reduce the number of grids displayed on the output layout and draw more attention to those who are speaking. You can hide inactive grids for any of the layouts except the Single view and Customized view.

To hide inactive grids, go to **Settings  > Video & Audio >** toggle on **Layout Reduction** and enter a delay time. If a channel is silent after, say 15 seconds (the delay time you set), their grid will be hidden.

Auto Mode (Active Position)

Active Position reports active talker positions from supported microphones in the form of X, Y, Z coordinates to deliver enhanced camera tracking.

Note: When using non-AVer cameras, only Live Mode and Manual Mode are available. Auto Mode (voice tracking) and camera control are not supported.

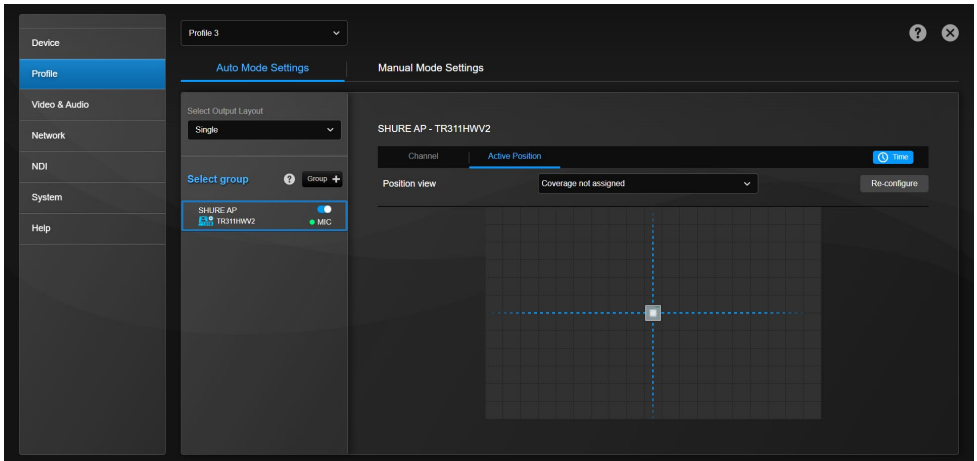

Supported Devices

USB- and IP-connected [supported AVer Devices](#)

Shure® MXA920-S / MXA920-R / MXA901 Ceiling Array Microphone

Note: For optimal audio tracking performance, you can go to Shure microphone web application to set the height value.

Square Microphone Calibration

1. Make sure the camera has been paired with a microphone.
2. Click to select a device group. A blue frame will indicate that it is selected.

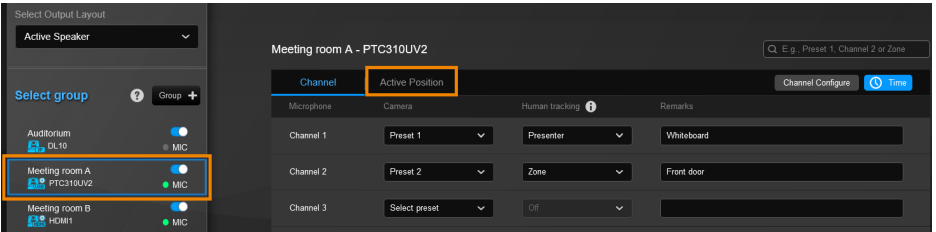

3. Click the **Active Position** tab and follow the setup wizard. Click the question mark in the top-right corner for instructions.

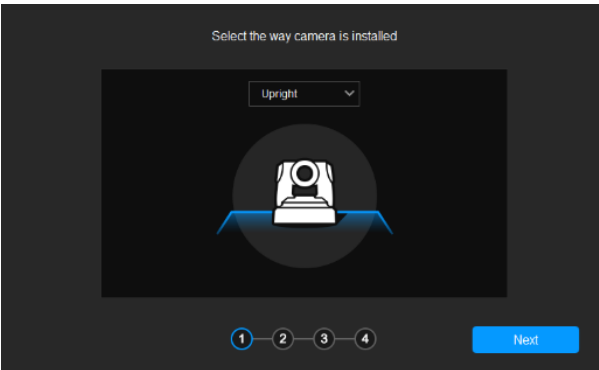

- ① Drag the red dot to align the red line to the top or bottom edge of the microphone.
- ② The microphone doesn't need to be in the center of the live view, as long as the red line is aligned to the edge. Adjust the camera angle using pan, tilt and zoom controls, if the microphone appears at a slight angle.

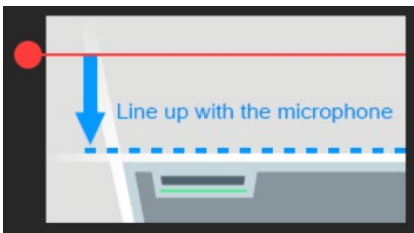

- ③ Starting from the top left, locate 3 microphone corners in a clockwise direction with a red cross.

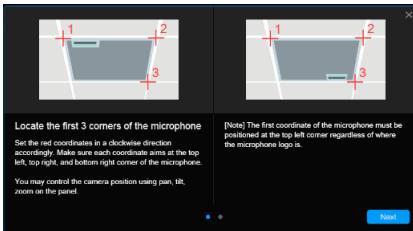

- ④ Click Set. The saved location will appear in the thumbnail.

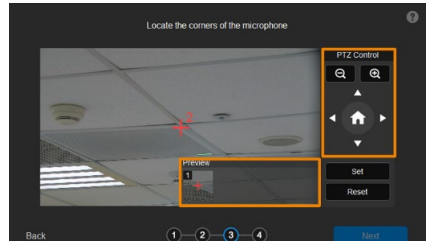

- ⑤ Finally, locate the logo on the microphone to indicate its orientation. Depending on the microphone orientation, the logo corner may be the same as one of the 3 corners.

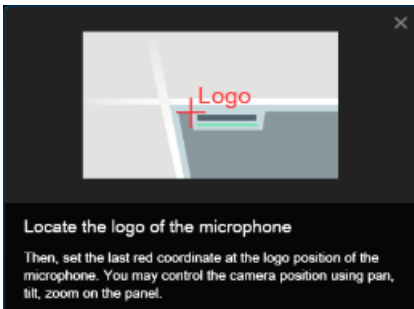

- ⑥ Click Next after locating 3 corners and the logo. Or click Reset to relocate all of them.

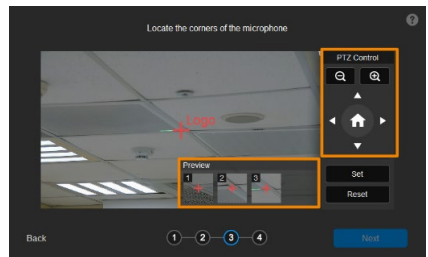

- ⑦ Make sure the red cross appears in the center of the microphone, and click Save. If the red cross appears off center, you can use a laser measure and tweak the initial calibration values (x, y, z) on the right.

- ⑧ Click Reset to restore the initial calibration values. Or click Back to reconfigure.

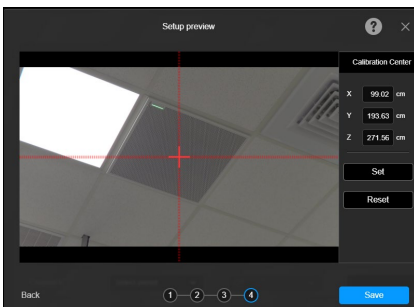

Round Microphone Calibration

1. Make sure the camera has been paired with a microphone.
2. Click to select a device group. A blue frame will indicate that it is selected.

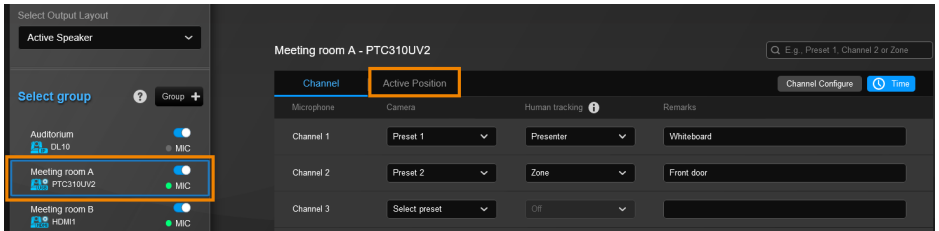

3. Click the **Active Position** tab and follow the setup wizard.
Click the question mark  in the top-right corner for instructions.

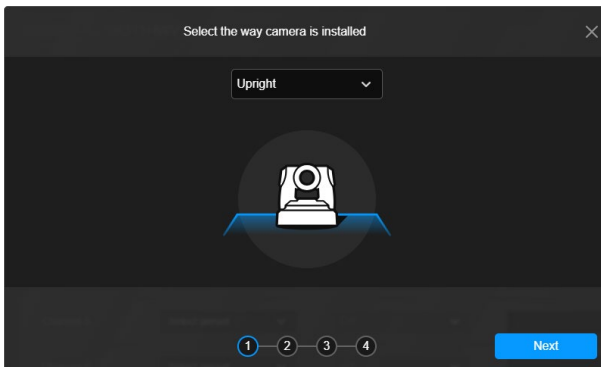

① Dragging the red dot to align the red lines to the top and left edge of the inner diameter so that the red cross appears at the center.

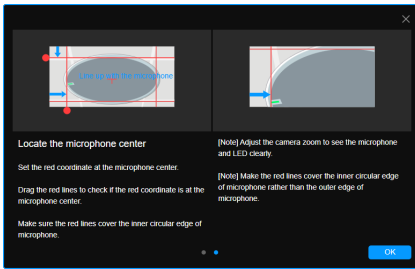

② Locate the top point of the inner diameter with the red cross.

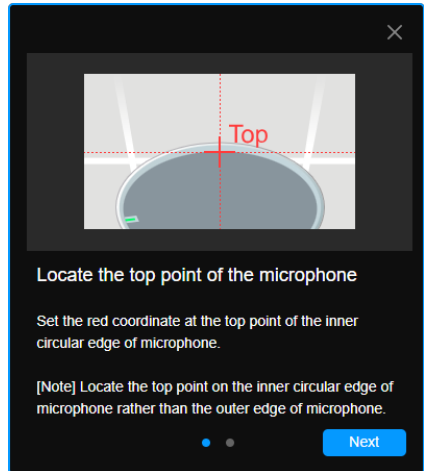

③ Click to mark the position of the LED.

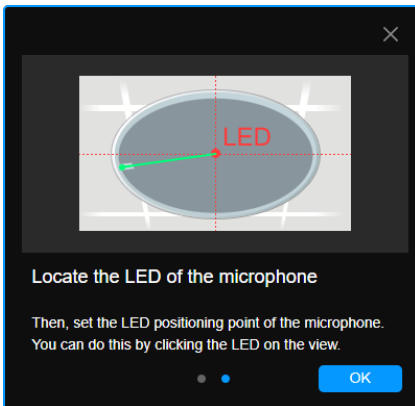

④ Make sure the red cross appears in the center of the microphone, and click Save. If the red cross appears off center, you can use a laser measure and tweak the initial calibration values (y, z, axis) on the right.

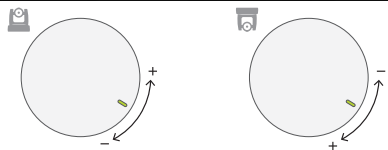
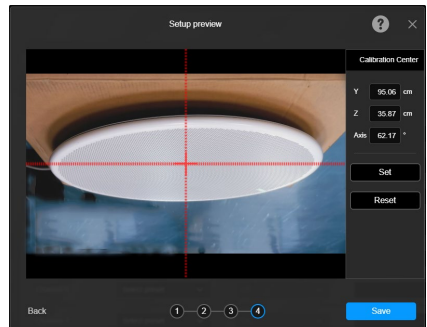

Note: When tweaking the axis value, the live view will not update. Adjust the initial axis value depending on how the camera is mounted. The axis angle range is -180 to 180.

- ⑤ Click Reset to restore the initial calibration values. Or click Back to reconfigure.

Add a Coverage Area

1. On the MXA920 web application, go to **Settings > General > Automatic coverage**.
2. Turn on **Automatic coverage** to add a mix of up to 8 dynamic and dedicated coverage areas,. The default setting is a 30 by 30 foot (9 by 9 meter) dynamic coverage area.

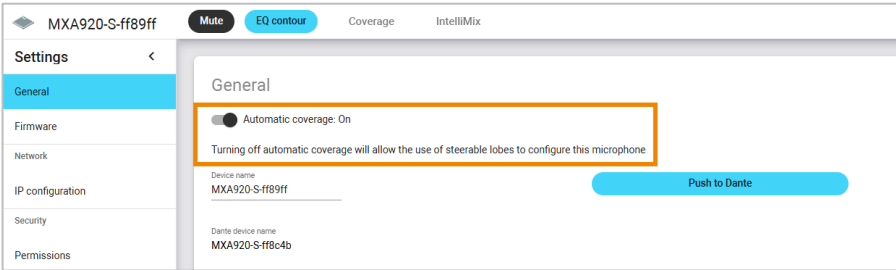

3. To add more coverage areas, go to **Coverage > Add coverage**.
4. Go to **Active Position** tab > select **Coverage not assigned** to use all coverage areas. Or select a coverage area that you have added in the microphone web application from the drop-down list. Talker positions outside of the selected coverage area won't be picked up by MT300.

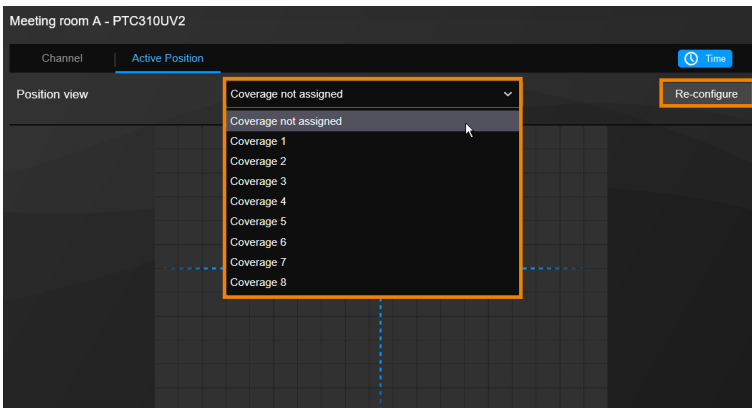

5. To change coverage areas, click **Re-configure**.
6. The profile is saved and applied automatically when you close the **Profile** page by clicking **X**. Your Auto Mode profile will now be applied.

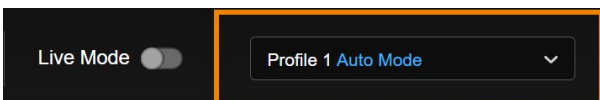

System Settings

Video & Audio

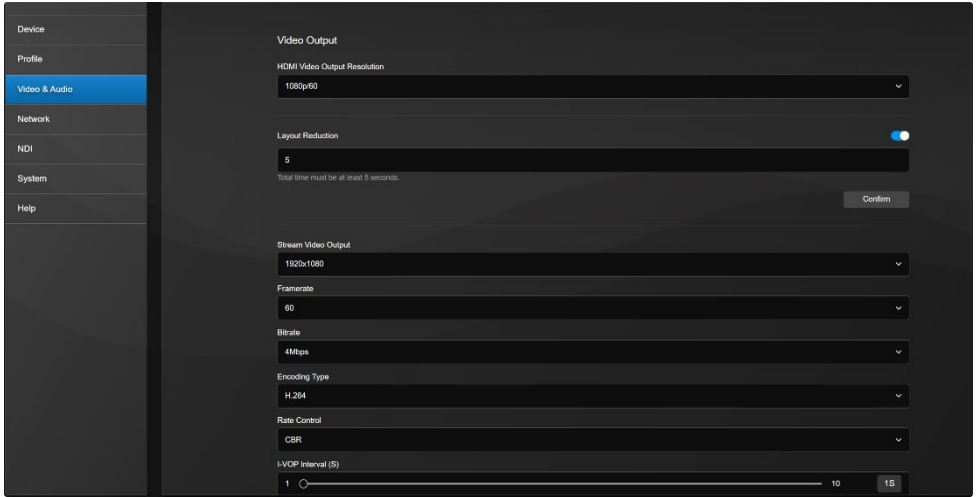

Video Output

Item	Description
HDMI Video Output Resolution	Choose a video output resolution.
Layout Reduction	When toggled on, the matrix box hides inactive channels to reduce the number of layout grids after the delay time you set.
Stream Video Output	Choose a streaming output resolution for the live view.
Framerate	Choose a framerate.
Bitrate	Choose a bit rate.
Encoding Type	Choose H.264 or H.265 .
Rate Control	Choose Variable Bit Rate (VBR) or Constant Bit Rate (CBR).
I-VOP Interval (S)	Sets how often a keyframe (or I-frame) is inserted in the video stream. <ul style="list-style-type: none">• A keyframe is a full image frame used as a reference point in video. Shorter intervals improve video quality, but increase file size.
USB Output	Choose a USB output source. <ul style="list-style-type: none">• Auto: Automatic detection.• USB #1: USB out port 1.• USB #2: USB out port 2.
Switching Camera Delay Time	Choose a delay time to avoid displaying the live view when the

	camera is in motion; it will refresh once the delay time is up.
Auto-center on speaker	<p>Keep the speaker at the center of the screen after the camera moves to a preset.</p> <p>Note:</p> <ul style="list-style-type: none"> • Auto-center on speaker is available in Auto Mode (Channel) only, for IP cameras and HDMI cameras (also connected via IP for PTZ control). • Human tracking must be turned off for this feature to work.

Audio Output

Item	Description
Enable UAC	Enable 1-way audio input from the camera to the computer.
2-way UAC	Enable audio input from the computer to speaker connected to the USB port 3 on MT300.

Network

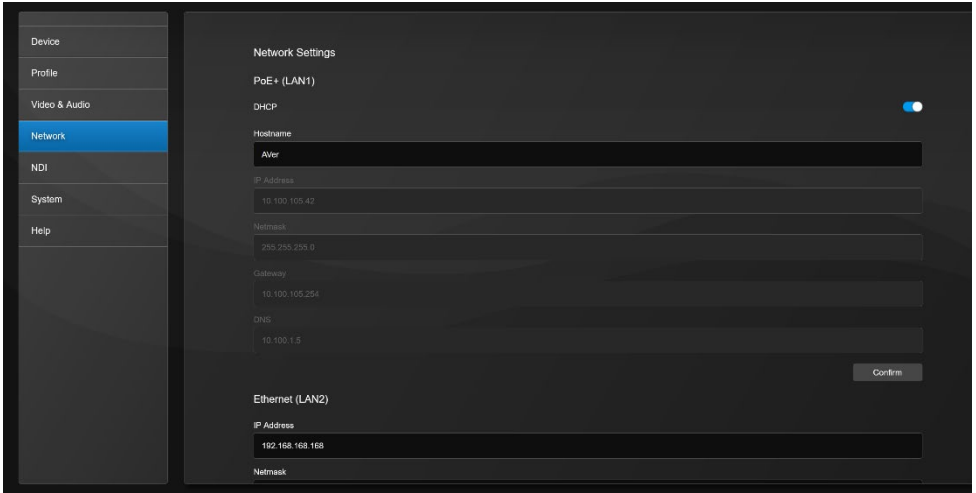

PoE+ (LAN1)

Item	Description
DHCP	Toggle DHCP on or off.
Hostname	Enter a hostname that is displayed on devices such as an IP router. The default is [Model name]-[last 6 digits of PoE+ MAC Address]
IP Address	Toggle off DHCP first, then enter your network settings to set up a static IP connection.
Netmask	
Gateway	
DNS	

Ethernet (LAN2)

Item	Description
IP Address	Enter your network settings to set up a static IP connection.
Netmask	
Gateway	
DNS	

RTMP Settings

Item	Description
RTMP Streaming 1	Stream live video to a video platform such as YouTube. To enable live streaming on YouTube:
RTMP Streaming 2	<ol style="list-style-type: none">1. Go to YouTube.2. From the top right, click Create > Go live.3. Copy and paste your YouTube server URL and stream key into the web interface.4. Click Start Stream to start streaming, Stop to stop streaming.

RTSP Settings

Item	Description
RTST Security	Turn on Real-Time Streaming Protocol (RTSP) Security to protect your video stream on media players such as VLC, PotPlayer and QuickTime by ensuring that only authorized users can access it. <ul style="list-style-type: none">• When RTSP Security is turned off, enter your camera's RTSP URL into the media player. RTSP URL: rtsp://[camera IP address]/live_st1 Example: rtsp://192.168.1.100/live_st1• When RTSP Security is turned on, enter your camera's RTSP URL and username/password into the media player. RTSP URL: rtsp://[username:password]@[camera IP address]/live_st1 Example: rtsp://1:1@192.168.1.100/live_st1 username/password: camera's username/password (web interface login)

HLS Settings

Item	Description
Stream URL	Configure HTTP Live Streaming (HLS) settings to provide adaptive bitrate streaming, which ensures smooth playback and minimizes buffering. <ol style="list-style-type: none">1. Enter the stream URL obtained from the streaming service or server.2. Click Start Stream to start streaming, Stop to stop streaming.

HTTP Settings

Item	Description
TCP Command String Control Port	Set a control port number. The default is 1315.
HTTPS	<p>Enable HTTPS to establish a secure connection between your browser and your camera.</p> <p>To enable HTTPS access on your camera:</p> <ol style="list-style-type: none">1. Obtain a SSL certificate for encryption and decryption in base-64 encoded format and use a private key in PKCS#8 format (unencrypted).2. Package the required certificate content into PEM format. The SSL certificate uploaded to the camera must be in PEM format.3. Click Browse to select the certificate file, and then click Upload.4. Turn on HTTPS.

NDI

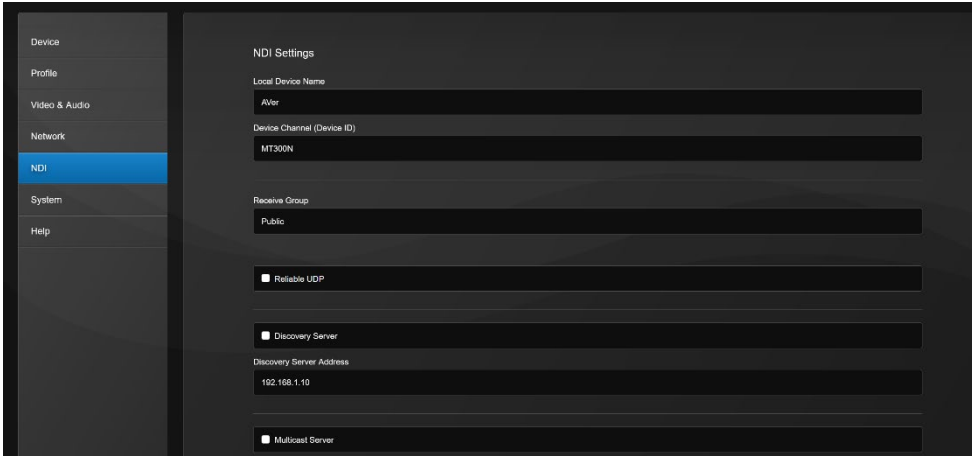

Tracking box comes in two models: MT300 (without NDI) and MT300N (with NDI). To purchase NDI|HX upgrade, please visit NewTek Online Store (<https://store.newtek.com/ndi-hx-upgrade-for-cameras.html#>).

Item	Description
Local Device Name	Enter a name that identifies your camera group on the NDI software.
Device Channel (Device ID)	Enter a name that identifies your camera on the NDI software. <ul style="list-style-type: none"> • The default is MT300 or MT300N. • Use no more than 10 characters, upper and lowercase letters, numbers and punctuation marks (! @ % ^ , . / : + ? [] { } - _ ~).
Receive Group	Enter a name for a receive group. <ul style="list-style-type: none"> • All devices in the receive group receive the same NDI streams. • The receive group should remain public. If this is changed, you will need to join the group through NDI® Access Manager.
Reliable UDP	Enable Reliable User Datagram Protocol (RUDP) to improve streaming quality.
Discovery Server	Select the checkbox to enable discovery server to allow devices to discover and connect to each other on a network automatically.
Discovery Server Address	Enter the IP address of a server running a discovery server

	application.
Multicast Server	Select the checkbox to enable multicast server to allow efficient distribution of NDI streams to multiple receivers without overwhelming the network.
Multicast Server Address	Enter the IP address of a group of recipients that receive NDI streams from a multicast server.
Multicast Server Mask	Enter the network mask to specify the range of IP addresses that are eligible to receive NDI streams.
Multicast TTL	Enter a multicast time to live (TTL) value between 1-255 to control the distance multicast packets can travel.

System

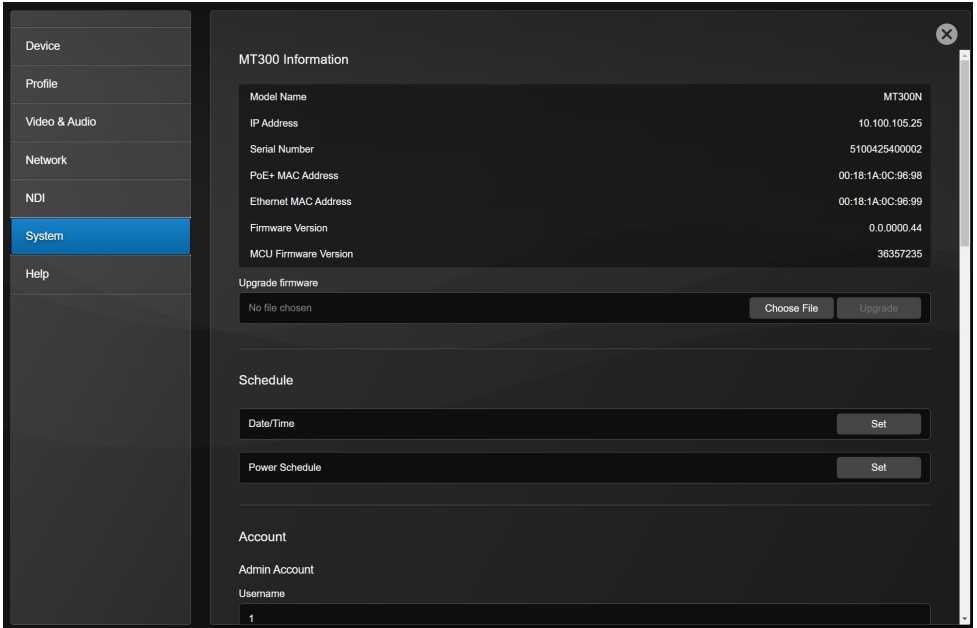

Item	Description
MT300 Information	Display MT300 information such as the IP address.
Upgrade Firmware	Download the latest firmware from AVer Download Center (https://www.aver.com/download-center).
Schedule	Date/Time: Set date and time for your tracking box. Power Schedule: Schedule specific times for your tracking box to start up, reboot, or shut down.
Account	Edit your admin and user account for login. <ul style="list-style-type: none"> Admin: The default username/password is admin/admin. User: The default username/password is user/user.
General	<ul style="list-style-type: none"> Language: Change the web interface language. Help us improve: Opt-in or opt-out of providing anonymous usage data. Factory default: Erase all data and settings and reset your tracking box to factory default settings. Reboot: Restart your tracking box.
Export / Import Settings	Export or import your tracking box settings and save debug files.
Shortcuts Key Setting	Set shortcuts for your USB keyboard or computer keyboard. You may set up to 36 shortcut keys.
Watermark Setting	Show or hide watermark on camera view. You may upload your

	<p>own watermark image, and select a watermark position from the drop-down list.</p>
--	--

- Support file format: PNG only.
- File size: Max. 2MB.

Help

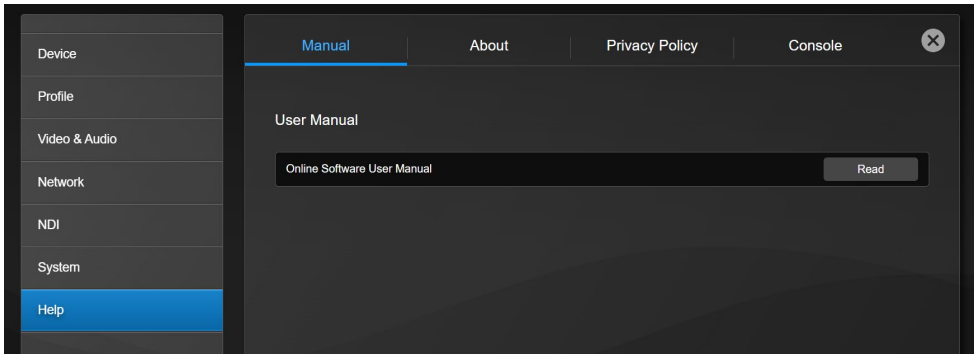

Item	Description
Manual	View software user manual online.
About	View software terms and condition.
Privacy Policy	View software privacy policy.
Console	View and download real-time data on the camera-microphone action status for debugging purpose.

MT Control Panel App



Control your AVer matrix boxes from a desktop, tablet, mobile or the AVer CP10 G2 Collaboration Controller. The app gives you access to the same settings as the web interface, with added convenience—as an admin, you can add up to 3 matrix boxes and easily switch between their video feeds.

- Available on Windows, macOS, and Android.
- Defaults back to the user account after closing and reopening the app to protect system settings.
- Supports:
 - MT100 Matrix Box
 - MT300 Matrix Tracking Box
 - MT300N Matrix Tracking Box
 - MT500 Matrix Tracking Box

Install MT Control Panel

Download and install MT Control Panel to your desktop, tablet or mobile from AVer Download Center. (<https://www.aver.com/download-center>) and open the app.

Note: For iPadOS and iOS, please download AVer Control Panel. This app gives you access to the same settings as the web interface.

Pair with MT Control Panel

1. Make sure the MT Control Panel and the matrix box are connected to the same LAN.
2. Open MT Control Panel app. The app will auto search for available matrix boxes. Or tap **IP Search** and enter your matrix box's IP address.
3. Tap to select your matrix box, tap **Pair**, then enter the username and password to start pairing.

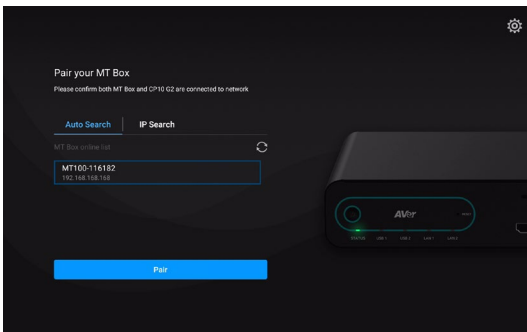

- You will now be logged in to the matrix box.
Configure settings as you would on its web interface.

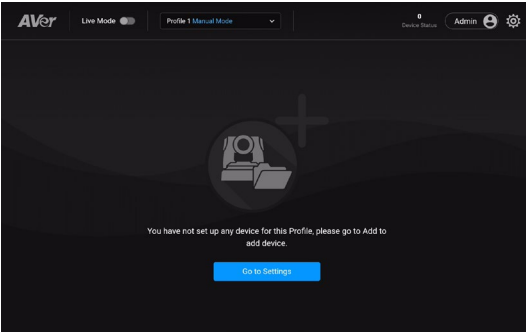

Add and Switch between Matrix Boxes

- Make sure you are logged in as an admin.
Or tap the **account** icon on the top-right corner to switch to the admin account.
- Tap the **gear** icon in the top-right corner to enter system settings.

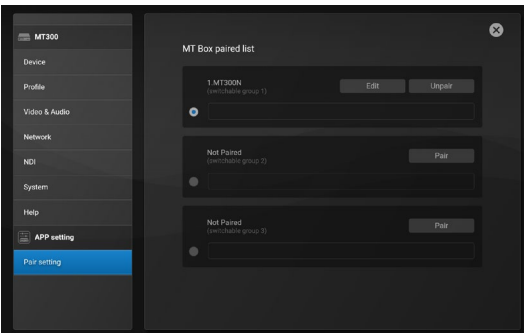

- Tap **Pair setting** and do one of the following:

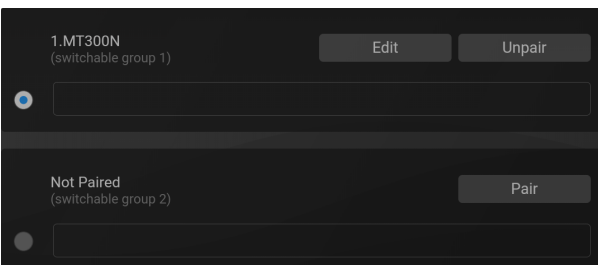

- To add a matrix box, tap **Pair**.

- To remove a matrix box, tap **Unpair**.
 - To replace a matrix box with another, tap **Edit**.
 - To switch between video feeds, tap the **radio button** to select the matrix box you want.
4. (Optional) Enter a description in the blank fields to help you identify the matrix boxes.

Specifications

DC Power	12V/1.5A
PoE+	42.5-57V / 0.6A
Reset Button	Yes
USB Inputs	3, Type-A for peripherals input #1,#2 are UVC only #3 can be UVC or UAC
USB Outputs	2, Type-B for user application Non-simultaneous output Automatic switch to the port that is connected to host. Port #1 has higher priority if both ports are connected to host (PC or MTR),. Resolution, providing 4K, 1080p FPS: 15, 30, 60
HDMI Inputs	3 Input resolution: up to 1080p per channel
HDMI Outputs	2 Simultaneous display, same configuration 1080p, 25Hz / 1080p, 50Hz / 1080p, 30Hz / 1080p, 60Hz / 4K, 25Hz / 4K, 50Hz / 4K, 30Hz / 4K, 60Hz
Ethernet	2, 1 PoE+, 1 RJ-45 Max connection number: 5 (Web/RTSP/RTMP) Resolution, providing 1080p and 4K FPS: 1, 5, 10, 15, 30, 60
LED Indicators	Yes Status, USB 1, USB 2, network 1, network 2
Security	Kensington security lock
RS-422	Yes
Operating Temperature	0-50°C
Dimension	4.3 x 21 x 15 cm (1.7 x 8.3 x 5.9 in.)
Installation	2, mountable in a rack or under a table

Specifications are subject to change without prior notice.

Troubleshoot

Using non-AVer cameras.

When using non-AVer cameras, only Live Mode and Manual Mode are available. Auto Mode (voice tracking) and camera control are not supported.

The device is optimized for AVer equipment. Performance with third-party cameras is not guaranteed.

No human tracking.

- Make sure your camera supports human tracking. For supported AVer devices, refer to [<Supported AVer Devices>](#).
- If your camera is connected via HDMI, make sure you select **Control via IP**.
Hover over the device in the device list and click the **Pencil** icon to edit.

Camera is too sensitive and flickering between presets.

- Select a longer duration for Time to Trigger Preset.
- If your camera is shared among several camera and microphone groups, [assign a priority group](#).

Stop voice-tracking.

- Click the **voice tracking** icon  on the main page to pause voice tracking for the current profile.
- Mute the microphone by pressing its physical button or accessing its web interface.
- Use the toggle switch on the Select Group Panel to disable the group.
Single video output: Audio is muted while video is still transmitting.
Multiple video output: Both audio and video stop transmitting.

Appendix

Supported AVer Devices

Note: When using non-AVer cameras, only Live Mode and Manual Mode are available. Auto Mode (voice tracking) and camera control are not supported. The device is optimized for AVer equipment. Performance with third-party cameras is not guaranteed.

Professional Tracking Cameras

- Single Lens

TR211	TR311HWV2	TR310
TR315	TR313V2	TR311
TR315N	TR323V2	TR311HN
TR335	TR323NV2	TR313
TR335N	TR333V2	TR331
TR615	PTC310HWV2	TR333
	PTC310UV2	PTC310
	PTC320UV2	PTC310N
	PTC320UNV2	PTC310U
	PTC330UV2	PTC330
		PTC330U

- Dual Lens

TR535	TR530+
TR535N	PTC115+
	PTC500+

Professional PTZ Cameras (no Human Tracking)

PTZ211	PTZ310
PTZ231	PTZ310N
PTZ310UV2	PTZ310W
PTZ310UNV2	PTZ330
PTZ330UV2	PTZ330N
PTZ330UNV2	PTZ330W

Video Conferencing Cameras (no Active Position)

CAM520 Pro3	VC520 Pro3
CAM550	VC550
CAM570	

Distance Learning Camera (no Active Position)

DL30

Supported Microphones

Important Note on Voice Tracking Installation

When installing voice tracking systems, consider the environment, materials, and distances to ensure optimal performance. Assess the room size, layout, and acoustics, as these factors impact accuracy. Different surfaces affect sound reflection and absorption, influencing effectiveness. Measure and maintain appropriate distances between devices and the coverage area for clear tracking. To achieve the best experience, connect with an AVer technical expert who can tailor the installation to your specific needs.

Note:

- Third-party microphone systems may require setup in their manufacture software.
- Make sure you have turned on **Multicast** on the router before setting up your microphone.

Audio-Technica

ATND1061DAN, ATND1061LK

ATUC-50

ATUC-IR

ESW - Engineered Sound® Wireless System

To set up ATND1061 Beamforming Ceiling Array Microphone:

1. Open Digital Microphone Manager. Go to **Settings & Maintenance**  > **System Settings** > **Network** > **IP Control Settings**.
2. Turn on **Notification** and **Camera Control Notification**.

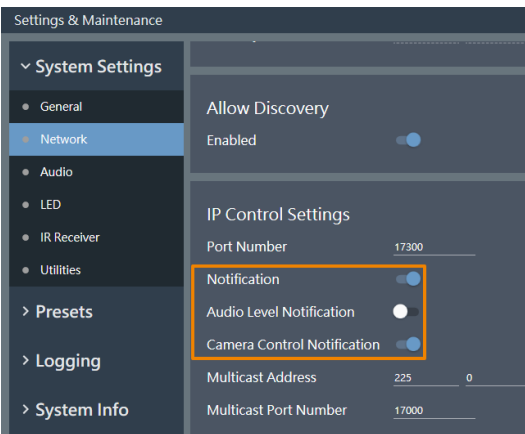

3. Select a microphone in the main area.
4. Go to **Camera > Camera Area**. Add a Camera Area by dragging it within the microphone pickup area. Each Camera Area group corresponds to MT300 channel 1-8.

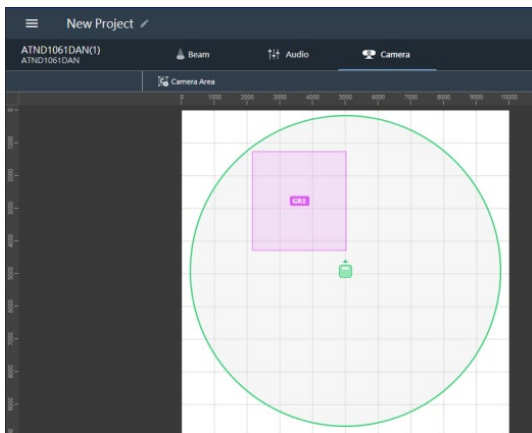

To set up ATUC-IRCU infrared control unit:

1. On the ATUC-IRCU Web Remote interface, go to **Settings & Maintenance > System Settings > Network > IP Control Settings**.
2. Turn on **Notification**.

Note: If a powered-off ATUC-IRDU appears to be sending audio signal in MT300, turn on **Audio Level Notification** to resolve the issue.

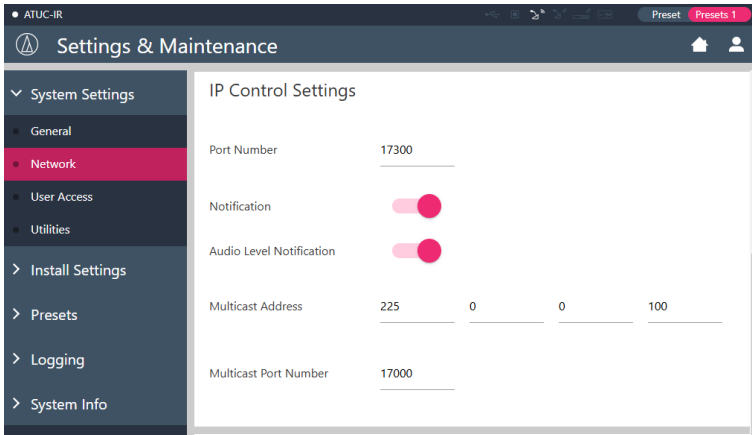

Pairing ATUC-50 with AVer camera presets for voice tracking :

- Each ATUC-50DU or ATUC-IRDU discussion unit corresponds to an MT300 channel.
- A discussion unit whose talk button is pressed first takes priority over others until it is mute. For example, Channel 1 (pressed first) takes priority over Channel 2 whose talk button is also pressed.

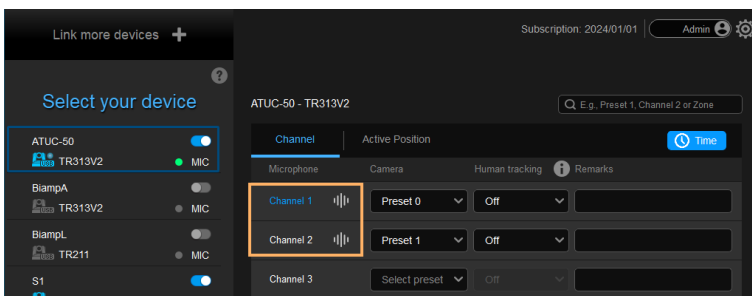

To set up Engineered Sound® Wireless System:

1. Open Wireless Manager and configure the links to each device.
2. You can reconfigure a transmitter's link to a different channel by dragging it there.
 - The linked channel number is mapped to the matrix box's channel of the same number.

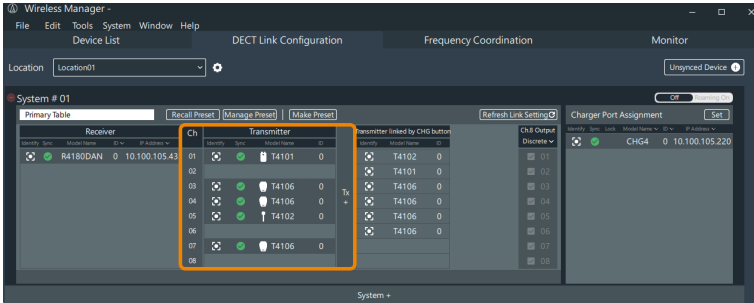

- Audio signals are displayed on the matrix box when sound is detected on a channel. The active channel is triggered by the channel with the highest audio level.

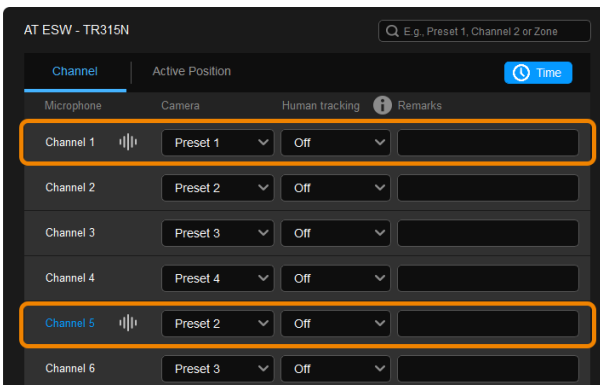
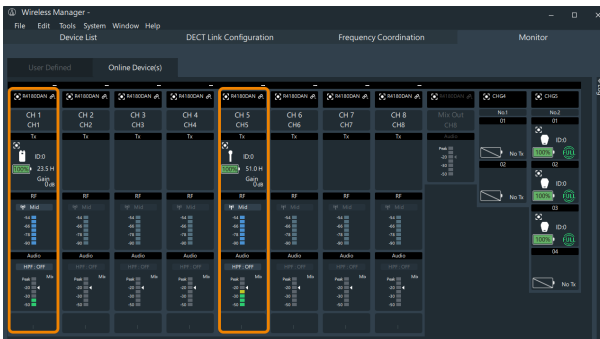

- Please note that the TCP port for the Engineered Sound® Wireless System is 17200, whereas the ATND1061 uses port 17300.

Table 2-1 Communication Interfaces

No	Item	Content	Remarks
1.	Communication system	Full duplex	
2.	Transmission speed	10Mbps / 100Mbps	
3.	Port number	TCP (control): 17200	Cannot be changed. (Fixed value)
		UDP (notification): 17000	Can be changed. (17000 at factory shipment)

Biamp

Tesira Digital Signal Processor

Parlé Ceiling Microphones (requires Parlé product revision A or B)

Hardware and Channels Overview

Tesira Digital Signal Processor	Tesira Forte X, Tesira Forte Rackmount, Tesira Server IO, Tesira Server.
Parlé TCM-X	Plenum network box + one ceiling-mount microphone array
Parlé TCM-XA	Plenum network box with built-in amplifier+ one ceiling-mount microphone array
Parlé TCM-XEX	One expansion ceiling-mount microphone array

One ceiling microphone arrays is permitted for network box (one TCM-X or TCM-XA with TCM-XEX).

Each ceiling microphone array has 8 channels. MT300 divides the microphones' horizontal angles into 8 equal parts, which correspond to MT300 Channel 1 - 8.

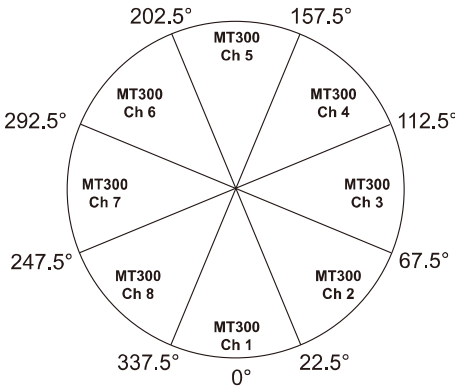

Microphone	Channel Start/End
AVerParleMic1	1-8 (ceiling mic 1) 9-16 (ceiling mic 2)
AVerParleMic2	17-24 (ceiling mic 1) 25-32 (ceiling mic 2)
AVerParleMic3	33-40 (ceiling mic 1) 41-48 (ceiling mic 2)
AVerParleMic4	49-56 (ceiling mic 1) 57-64 (ceiling mic 2)
AVerParleMic5	65-72 (ceiling mic 1) 73-80 (ceiling mic 2)
AVerParleMic6	81-88 (ceiling mic 1) 89-96 (ceiling mic 2)

To enable system security:

You can protect 3rd party media control access for the Tesira system using username and password.

1. After the DSP has been configured, connect to the unprotected Tesira system with Tesira Designer Software.
2. Open the **System** page > **Security** menu > **Manage System Security...**
3. Click the **Protect System...** button to create the admin user and password.

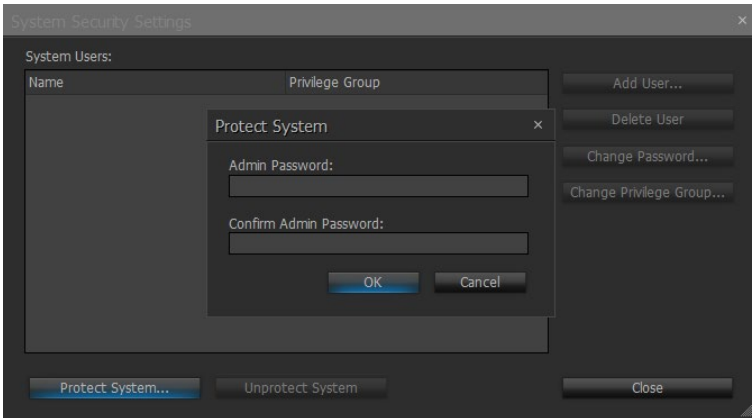

4. You'll be prompted to enter the same set of username and password when connecting to Biamp microphones in MT300.

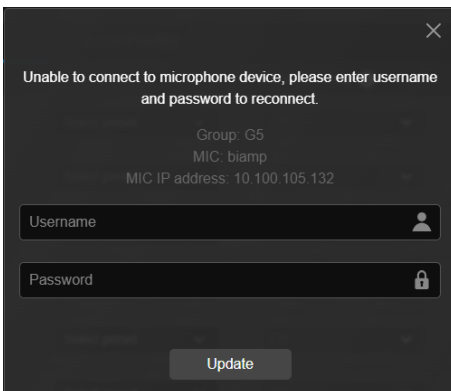

- Logic Meter block: **AVerMeterX** (X=1–4 starting with 1)

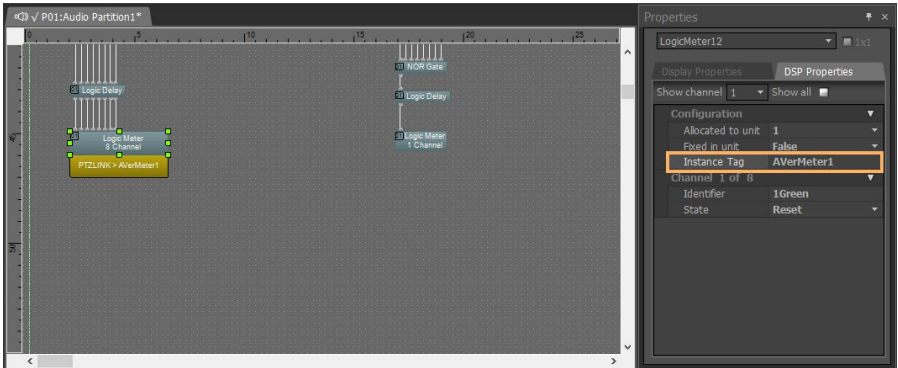

3. Click **Channel Configure** and select a pickup mode in MT300. Then lick **Save**.

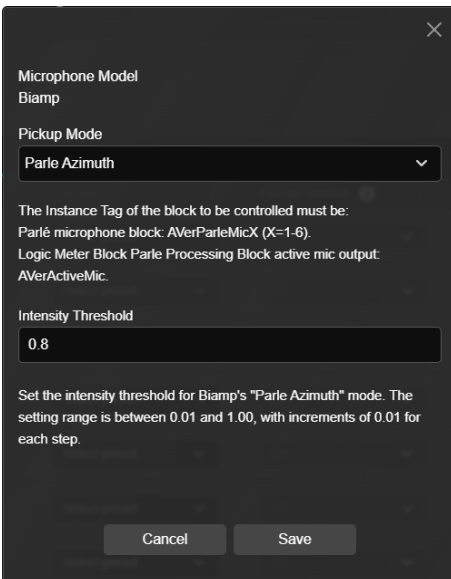

Bosch

CCS 1000 D Digital Discussion System
DICENTIS Wireless Conference System
DICENTIS Conference System

- Each CCS 1000 D Control Unit supports up to 80 Discussion Devices.
- Assign each CCS 1000 D Discussion Device to one MT300 channel by changing the seat name.
- A discussion unit whose talk button is pressed first takes priority over others until it is mute. For example, Channel 1 (pressed first) takes priority over Channel 2 whose talk button is also pressed.

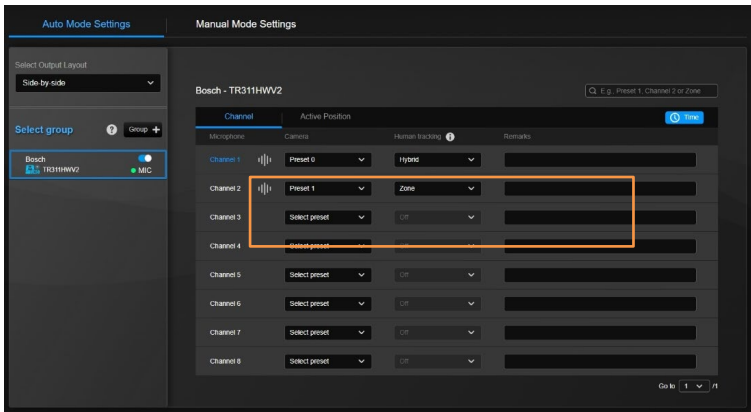

To set up CCS 1000 D:

1. Connect to the CCS 1000 D Control Unit through IP. Access the web interface with an administrator account.
2. Go to **System Settings > Users**, create a user for MT300 with the default username/password **ptzlink/ptzlink**. The password can be changed later. For **User rights**, select **Manage meeting**.

The screenshot shows the 'User settings' page with a modal dialog for adding a new user. The dialog contains the following fields and options:

- First name:** AVer
- Last name:** Information
- Username:** ptzlink
- Password:** ptzlink
- Confirm password:** ptzlink
- User rights:** Manage meeting (selected), Configure, Prepare meeting, Prepare system, Modify users

Buttons: Cancel, Save, Change password

3. Go to **System Settings > Network and general settings > General settings**, deselect **Automatically shut down the system when not used** to avoid entering standby mode.

The screenshot shows the 'Network and general settings' page with the following sections:

- Network settings:** Hostname: ccs1000d
- Wired:** Fixed IP: No
- General settings:** Automatically shutdown the system when not used

Buttons: Change network settings, Factory default

4. Go to **System Settings > Seats**, rename the **Seat name** ending with a space and a number to assign each discussion device to one MT300 channel of the same number.

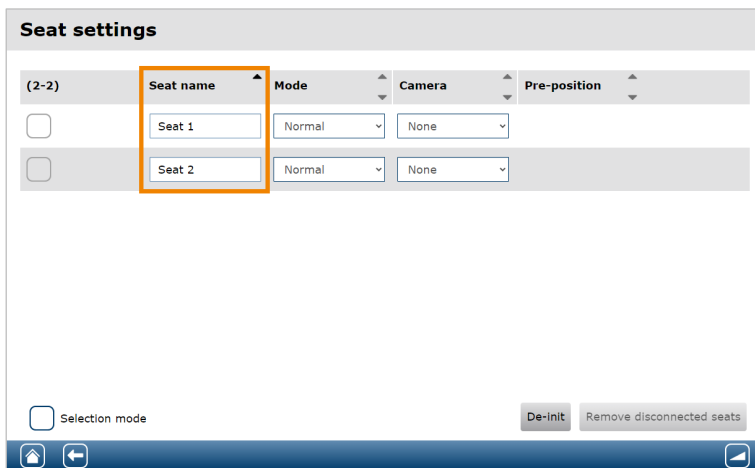

Seat 1 corresponds to channel 1, seat 2 to channel 2, and so on.

5. You'll be prompted to enter the same set of username and password when connecting to Bosch microphones in MT300.

Note: CCS 1000 D Control Unit allows one login at a time. When connecting CCS 1000 D Discussion Devices to MT300, make sure you are not logged in anywhere else.

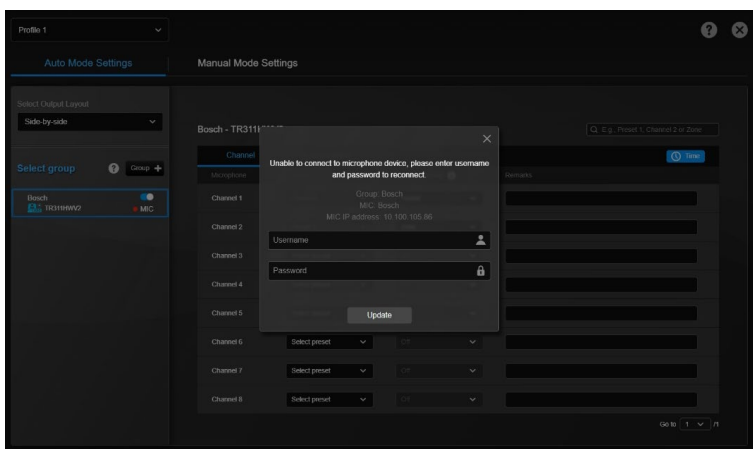

- **To log in to DICIENTIS System Server:**

1. Open **Remote Desktop Connection** on your computer. Enter the DICIENTIS server name printed on the product label.

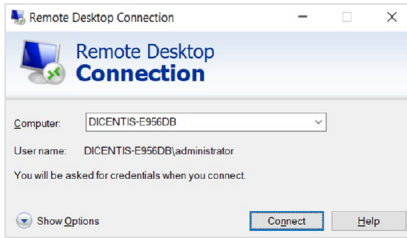

2. Enter the credentials you purchased from Bosch. On security message pop-up window, click **Yes**.

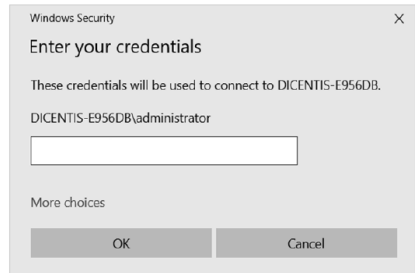

3. Open **Bosch Meeting Application**, enter your credentials to log in. Go to **Configure** for further meeting room and user settings.



4. Click **Users** and click the Add icon to add a new user. In **Security**, select **Admin** as the User group, and then click **Change Password**.

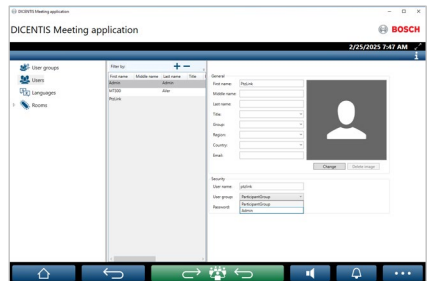

5. Enter the default password: **ptzlink**. When finished, click **OK**.

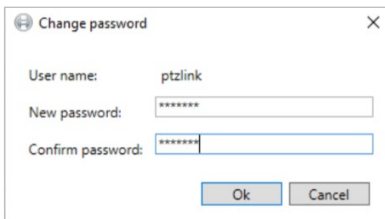

6. Go to **Rooms > Seats and devices** to assign each microphone to MT300 channels. Seat 1 corresponds to channel 1, seat 2 to channel 2, and so on.

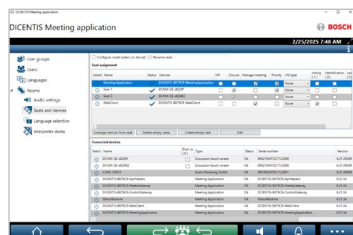

ClearOne

BMA 360 + CONVERGE® Pro 2 DSP Mixers

- CONVERGE® Pro 2 connects up to 3 daisy-chained BMA 360 microphone arrays.
- MT300 assigns 12 channels to each BMA 360. Unused channels are retained in the assigned BMA 360.

Daisy-Chained	Channel Start/End
1 st BMA 360	1-12
2 nd BMA 360	13-24
3 rd BMA 360	25-36

- When adding your device in MT300, select your MIC channels in the drop-down list according to the number of BMA 360 daisy-chained.

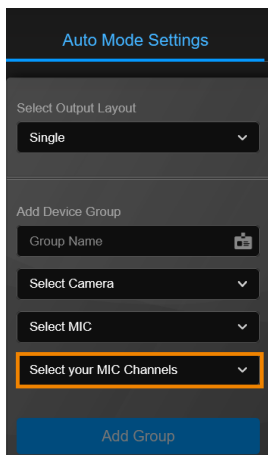

BMA 360D

- Use CONSOLE AI Lite software to select preset beam patterns for common room or custom pattern for unique floorplans of up to 12 beams.
- Each microphone beam corresponds to one MT300 channel of the same number.

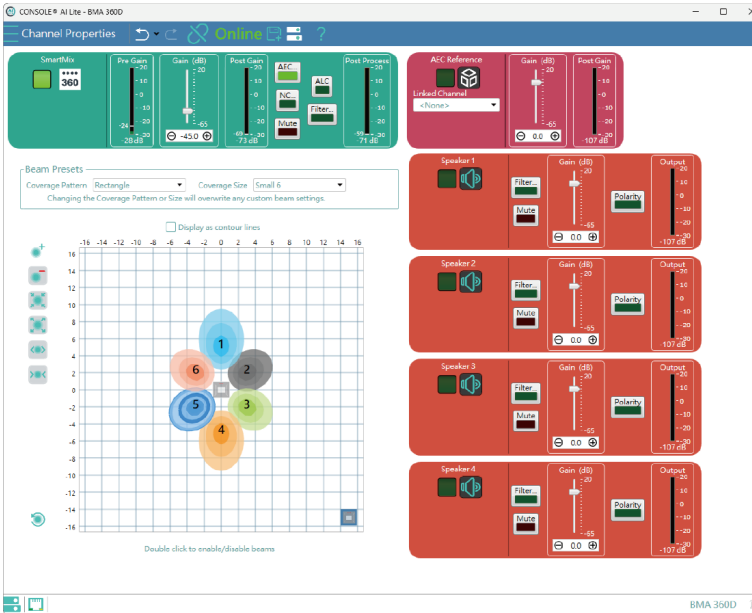

BMA 360DX

To set up BMA 360DX:

1. Connect the BMA 360DX to the CONSOLE One software to select preset beam patterns for common room or custom pattern for unique floorplans of up to 12 beams.
2. Go to **Channel Properties** > click **DX** next to **Beamformer**.

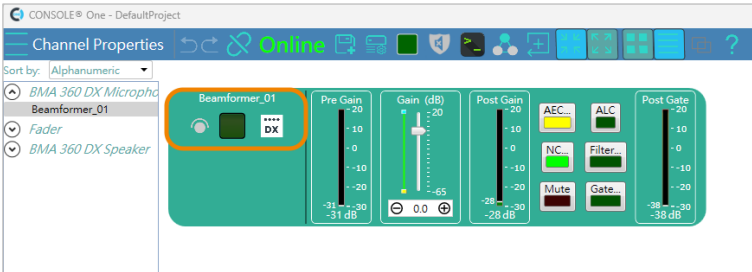

3. Go to **Advanced** > deselect **Last Beam On**.

This prevents the last active channel from appearing active in MT300 when the room is silent.

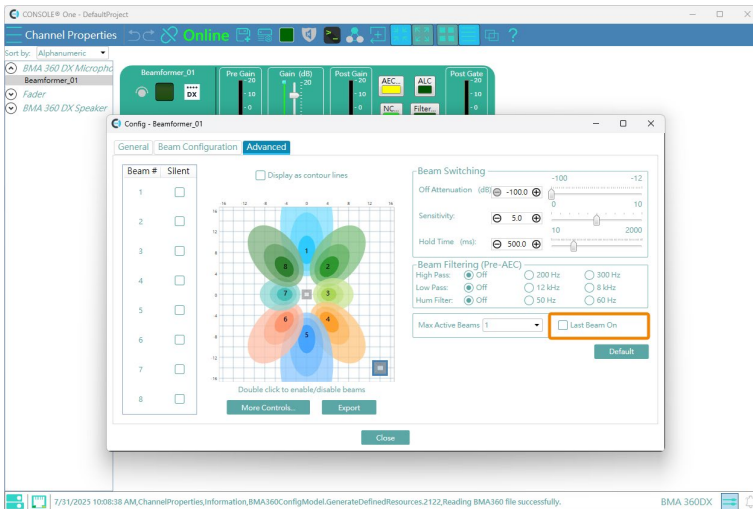

4. Each microphone beam corresponds to one MT300 channel of the same number.

Nureva

HDL300

HDL310

Dual HDL300

HDL410

To set up HDL microphones:

1. In Nureva Console Client, turn on **Enable camera tracking integration**, then enter the IP address of the MT300 in the **Allowed host names / IP addresses** field.

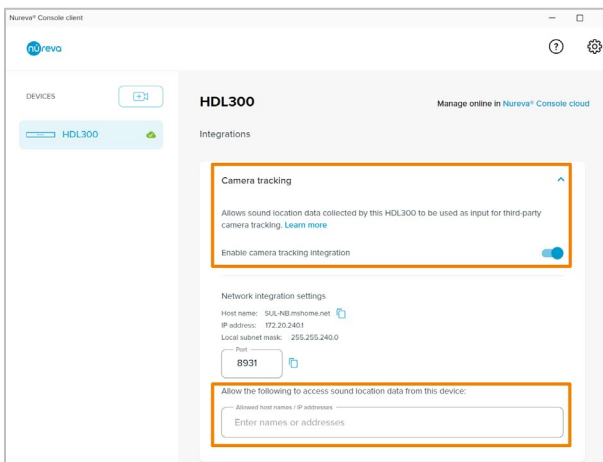

2. On the MT300 web interface, enter the IP address of the computer running Nureva Console Client in the **IP Address** field when adding microphones.
MT300 divides HDL microphones' horizontal angles into 8-24 equal parts, which correspond to MT300 channel 1-24.

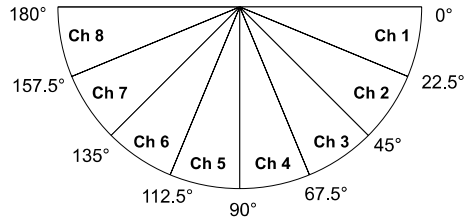
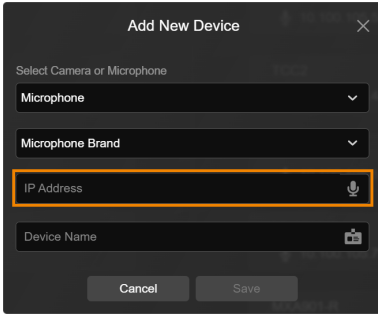

To add a coverage area for HDL410 in MT300:

1. Go to **Auto Mode Settings > Channel > Channel Configure**.

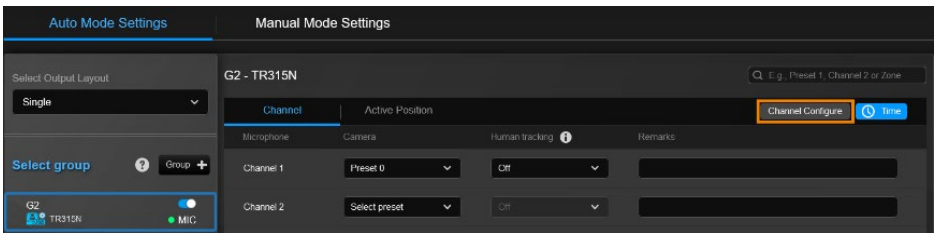

2. Select **Coverage** from the **Pickup Mode** drop-down list.
3. Click **Coverage Map Setting** > Click **Add Coverage**.

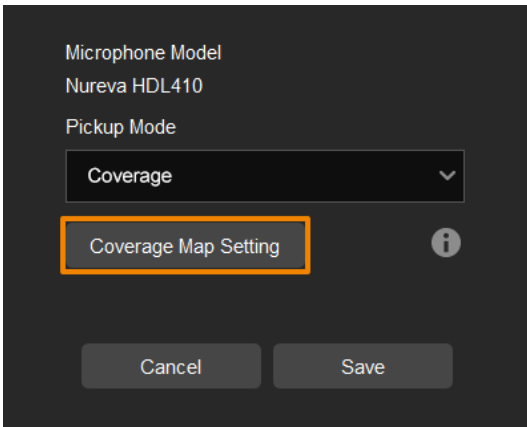

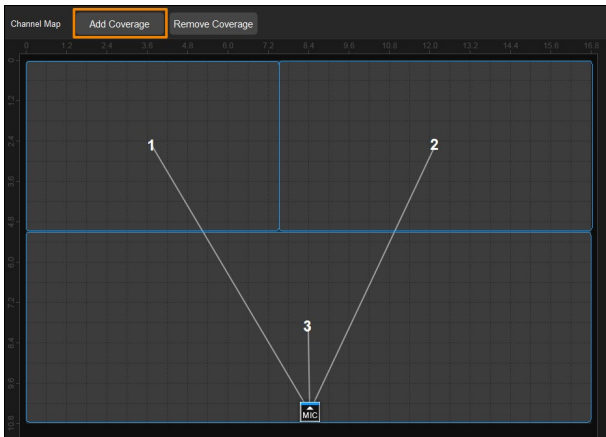

4. Add a coverage area by dragging it.

- You can add up to 8 coverage areas per microphone.
- When coverage areas overlap, the microphone will default to the area with the smaller number.

Sennheiser

TeamConnect Ceiling 2

TeamConnect Ceiling Medium

EW-DX EM 2 Half Rack Receiver

EW-DX EM 2 Dante Half Rack Receiver

EW-DX EM 4 Dante Full Rack Receiver

EW-DX TS 3-Pin Table Stand Transmitter (and compatible microphones)

EW-DX TS 5-Pin Table Stand Transmitter (and compatible microphones)

MT300 divides TeamConnect Ceiling 2's and TeamConnect Ceiling Medium's horizontal angles into 8-24 equal parts, which correspond to MT300 channel 1-24.

- **TeamConnect Ceiling 2**

An Exclusion Zone set in Sennheiser Control Cockpit also affects the corresponding channel in MT300.

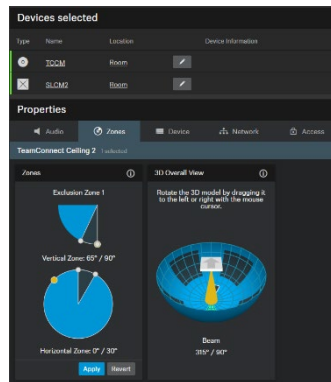
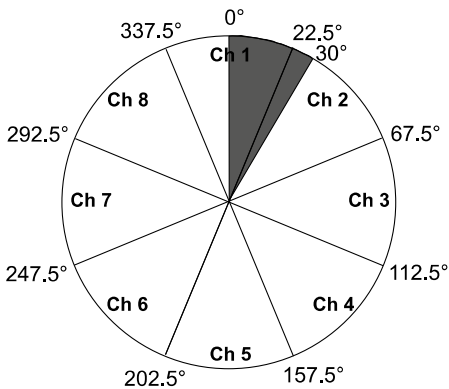

Sennheiser Control Cockpit

- **TeamConnect Ceiling Medium**

The 3rd party media control access for TeamConnect Ceiling Medium is encrypted and protected using username and password. It has to be enabled using Sennheiser Control Cockpit before use.

To set a 3rd Party device control password:

1. Open Sennheiser Control Cockpit. Go to the **Access** tab in the device configuration page.

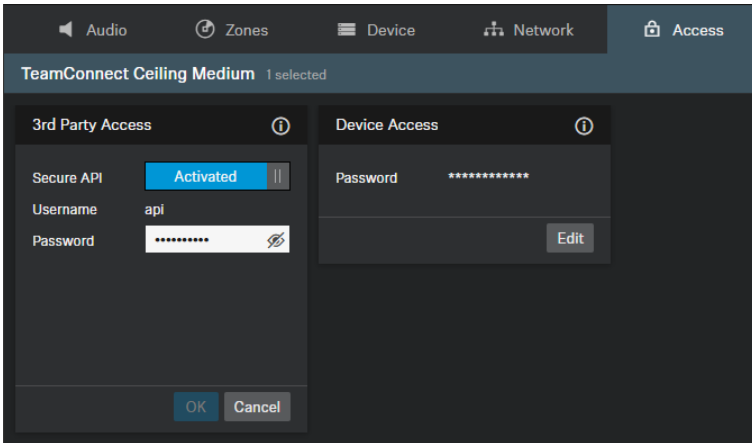

2. Activate the toggle switch.
3. Enter a password.
4. You can use the username "api" and configured password for your API calls.

Note:

- If you deactivate 3rd party access, the previously set password will be deleted.
- Password must be at least 10 characters and no more than 64 characters. Use at least one lowercase letter, one uppercase letter, one number and one special character (!#\$%&()*+,-./:;<=>?@[^_{}~).

- **EW-DX EM 2, EW-DX EM 2 Dante, EW-DX EM 4 Dante**

The 3rd party media control access for EW-DX EM receivers is encrypted and protected using username and password. It has to be enabled using Sennheiser Control Cockpit before use.

Important: For compatibility with EW-DX firmware version 4.0.0, MT300 firmware version 0.1.0000.82 or later is required.

To set a 3rd Party device control password:

1. Open Sennheiser Control Cockpit. Go to the **Access** tab in the device configuration page.

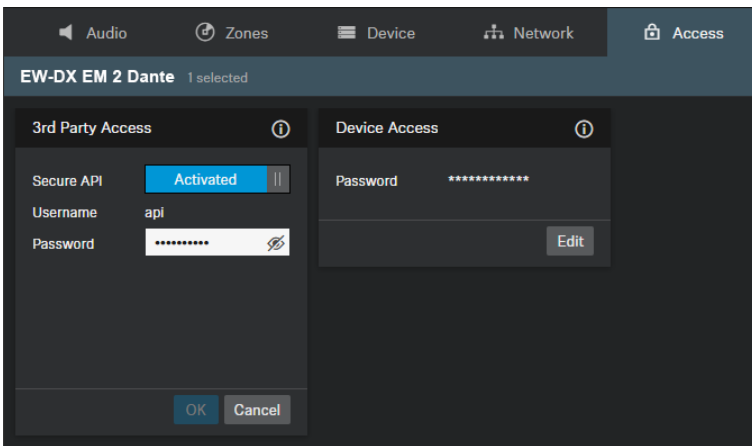

2. Activate the toggle switch.
3. Enter a password.
4. You can use the username "api" and configured password for your API calls.

Note:

- If you deactivate 3rd party access, the previously set password will be deleted.
- Password must be at least 10 characters and no more than 64 characters. Use at least one lowercase letter, one uppercase letter, one number and one special character (!#\$%&()*+,-./:;<=>?@[^_{}~).

- **EW-DX EM 4 Dante Receiver and Transmitters**

Each transmitter will connect to EW-DX 1-4, which correspond to MT300 channel 1-4.

You can log in to Sennheiser Control Cockpit to view the status of each transmitter.

For connecting the receiver with the transmitters, please refer to Sennheiser official website:

<https://docs.cloud.sennheiser.com/en-us/ew-d/ew-d/ew-dx-connecting-synchronizing-em.html>

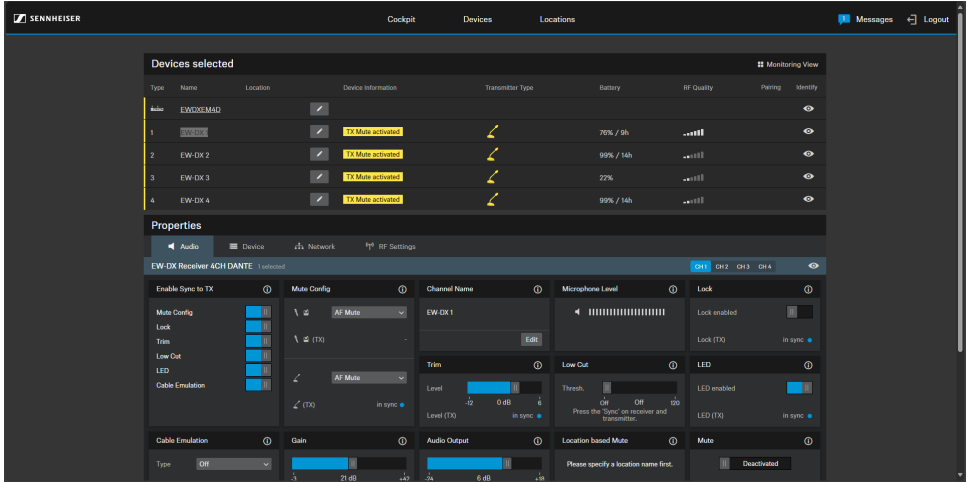

Shure

Shure® IntelliMix® P300 Audio Conferencing Processor

Shure® IntelliMix® Room Audio Processing Software

Shure® MXA310 Table Array Microphone

Shure® MXA710 Linear Array Microphone

Shure® MXA910 Ceiling Array Microphone

Shure® MXA901 Conferencing Ceiling Array Microphone

Shure® MXA920-S / MXA920-R Ceiling Array Microphone

Shure® Microflex® Complete Wireless (MXCW) System

• Shure® IntelliMix® P300 Audio Conferencing Processor

When the microphone picks up audio from far-end participants on a video conferencing software, the group's camera moves to preset 0. This purpose of this feature is to show the whole room and prevent false tracking.

To set up far-end speaker detection:

1. Add your devices (e.g., P300 and MXA920) in Shure Designer.
2. Route your devices.

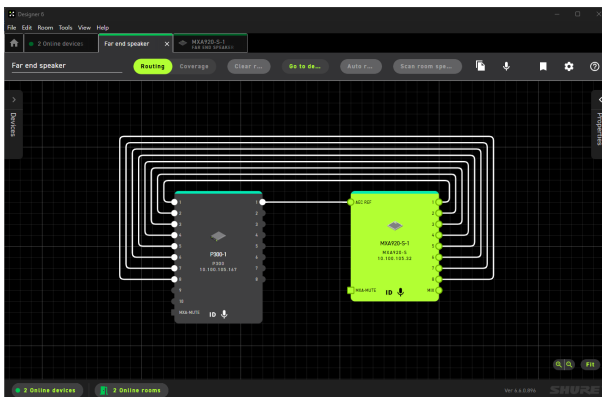

3. Add P300 and your camera in the matrix box's web interface.

Go to **Settings** ⚙️ > **Device** > **Add device**, then add the P300 as microphone.

4. Create your camera and microphone group in the matrix box's web interface.

Go to **Settings** ⚙️ > **Profile** > **Select group**, then click **Group +** to create a group.

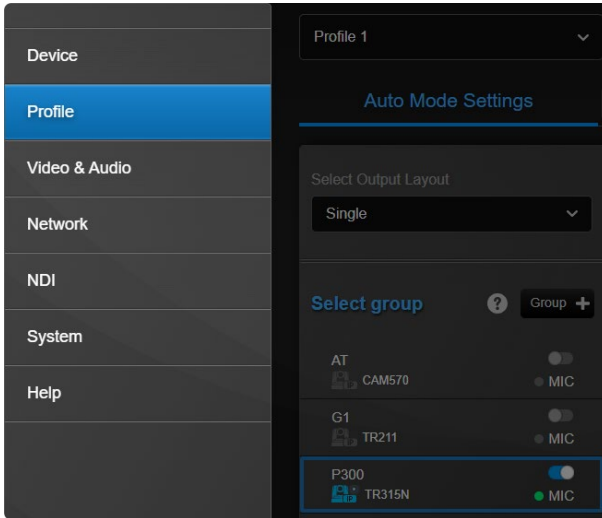

5. Pair presets and microphone channels.
6. Click **Time** ⌚ to configure **Far end speakers trigger preset 0**.
7. Start a meeting on your video conferencing software and select P300 as audio.
8. When the microphone picks up audio from far-end participants, the most recently used camera should move to Preset 0 after the configured delay.

- **MXA310 Table Array Microphone**

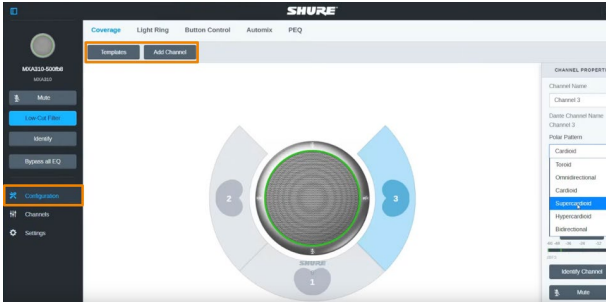

Web Application

1. Open the **Configuration** tab.
2. Select **Template** to apply a multi-channel option or select **Add Channel** to add more than 1 channel. MT300 does not support a single channel for the MXA310.

- **MXA910 Ceiling Array Microphone**

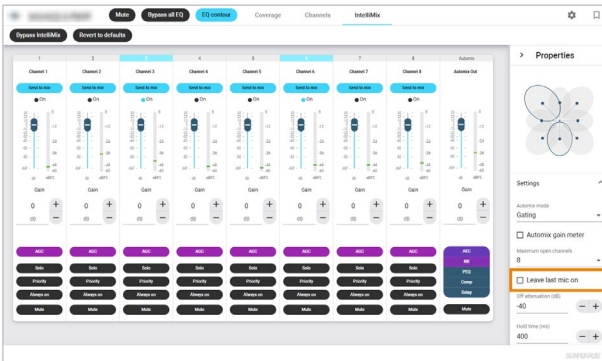

Web Application

Go to **IntelliMix > Automixer Properties > Deselect Leave last mic on.**

- **MXA920-S / MXA920-R / MXA901 Ceiling Array Microphone**

Note: To integrate with supported AVer camera tracking system via active talker positions, refer to [<Auto Mode \(Active Position\)>](#).

To manually position up to 8 lobes:

1. In the microphone's web application, go to **Settings > General > Turn off Automatic coverage.**

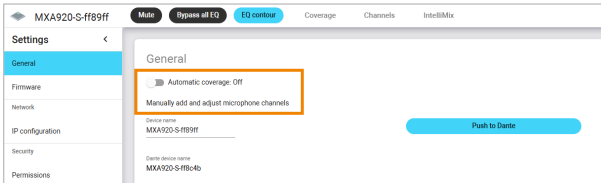

2. Go to **IntelliMix > Automixer Properties > Deselect Leave last mic on.**

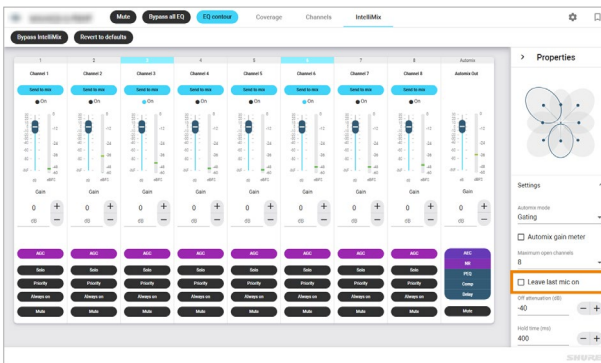

3. In the matrix box's web interface, go to **Auto Mode Settings > Channel > Channel Configure > Select Lobe as Pickup Mode:** The lobes you have positioned in the microphone's web application correspond to MT300 channel 1-8.

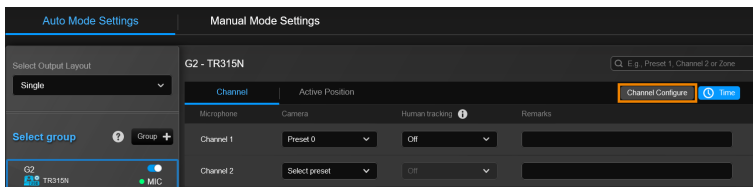

4. Select one of the following from the **Channel Information** drop-down list:
- Automixer Gate Out (default): Detects all sounds
 - Talker Position: Detects active talkers

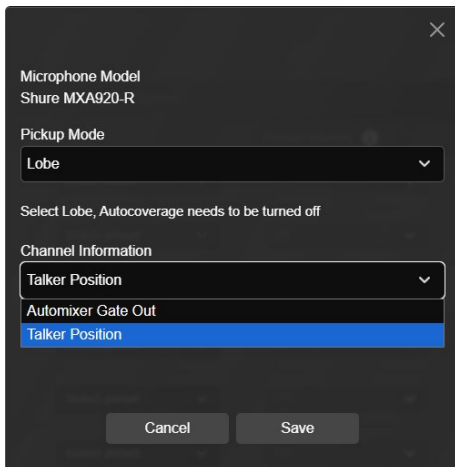

Microphone Model
Shure MXA920-R

Pickup Mode
Lobe

Select Lobe, Autocoverage needs to be turned off

Channel Information
Talker Position
Automixer Gate Out
Talker Position

Cancel Save

To add a mix of up to 8 dynamic and dedicated coverage areas:

1. In the microphone's web application, go to **Settings > General > Turn on Automatic coverage**. The default setting is a 30 by 30 foot (9 by 9 meter) dynamic coverage area.

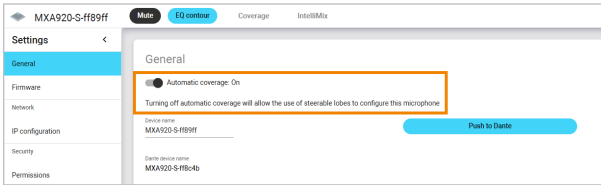

2. To add more coverage areas, go to **Coverage > Add coverage**.
3. In the matrix box's web interface, go to **Auto Mode Settings > Channel > Channel Configure > select Coverage as Pickup Mode**. The coverage areas you have positioned in the microphone's web application correspond to MT300 channel 1-8.

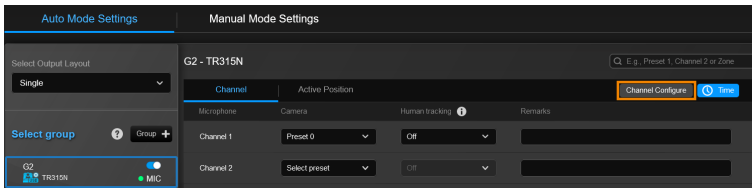

4. Select one of the following from the **Channel Information** drop-down list:
 - Automixer Gate Out (default): Detects all sounds
 - Talker Position: Detects active talkers

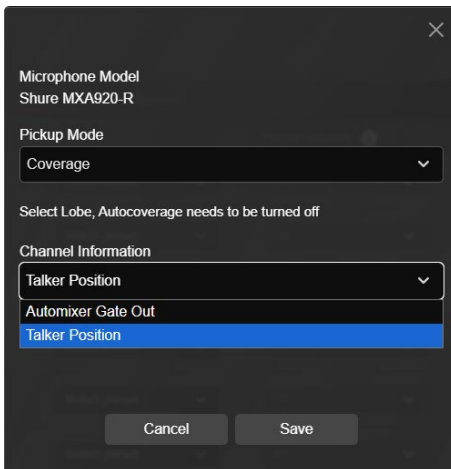

To add up to 16 dedicated coverage areas:

1. In the matrix box's web interface, go to **Auto Mode Settings > Channel > Channel Configure > select Talker Position as Pickup Mode.**

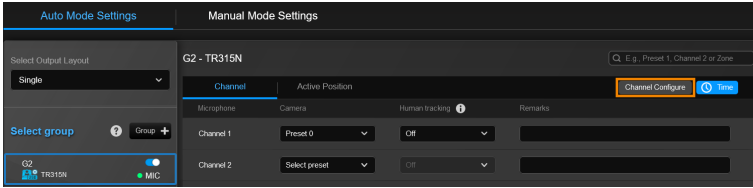

2. Click **Map Setting > Add Zone.**

You can add up to 16 coverage areas per microphone. Move and resize as needed.

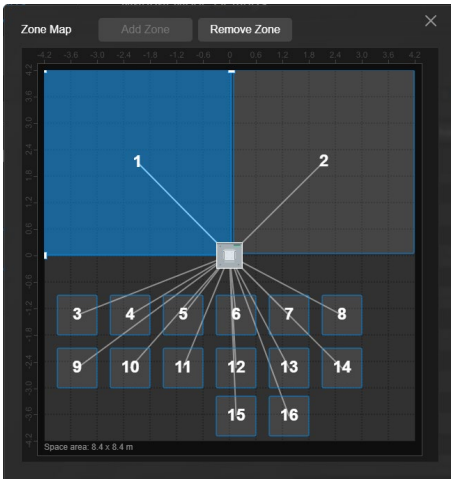
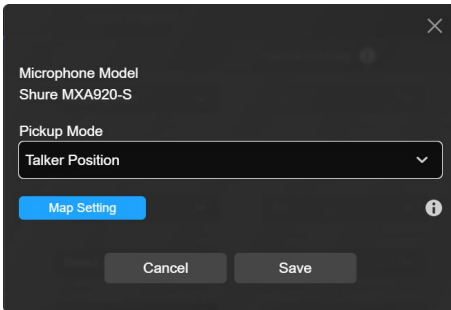

Yamaha

RM-CG Ceiling Array Microphone

RM-TT Tabletop Array Microphone

RM-CR Remote Conference Processor

RM-W Wireless Microphone System

- MT300 divides RM-CG's horizontal angles into 8-24 equal parts, which correspond to MT300 channel 1-24.

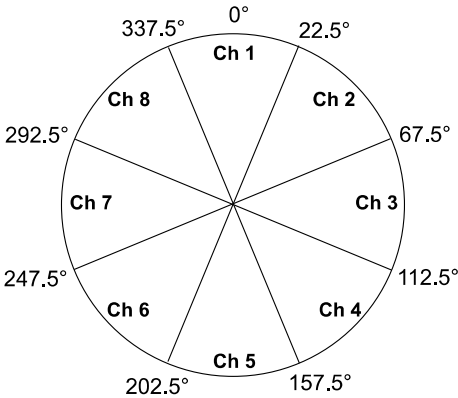

- MT300 voice tracking function requires linking more than one RM-TT or RM-W microphones for location data.
- When linking RM-TT or RM-W microphones to the RM-CR Remote Conference Processor, enter the processor's IP address in the **IP Address** field when adding microphones in MT300.

The screenshot shows the 'Add New Device' dialog box. The title bar contains the text 'Add New Device' and a close button (X). Below the title bar is the text 'Select Camera or Microphone'. There are four input fields: 'Microphone' (dropdown menu), 'Microphone Brand' (dropdown menu), 'IP Address' (text field with a microphone icon and a red border), and 'Device Name' (text field with a plus icon). At the bottom are 'Cancel' and 'Save' buttons.

Set 2-way UAC	http://[account]:[password]@[IP Address]/cgi-bin?Set=TrkBox_Two_way_uac_on,3,0 http://[account]:[password]@[IP Address]/cgi-bin?Set=TrkBox_Two_way_uac_on,3,1	0: disable 1: enable
Get USB output	http://[account]:[password]@[IP Address]/cgi-bin?Get=TrkBox_Usb_output_switch	0: Auto 1: USB#1 2: USB#2
Set USB output	http://[account]:[password]@[IP Address]/cgi-bin?Set=TrkBox_Usb_output_switch,3,0 http://[account]:[password]@[IP Address]/cgi-bin?Set=TrkBox_Usb_output_switch,3,1 http://[account]:[password]@[IP Address]/cgi-bin?Set=TrkBox_Usb_output_switch,3,2	0: Auto 1: USB#1 2: USB#2
Get device status	http://[account]:[password]@[IP Address]/request=queryDeviceStatus	Device Info: name=device name, type=camera or microphone, port=USB1~3, HDMI1~3, or IP status=online or offline
Get general mode	http://[account]:[password]@[IP Address]/request=getGeneralMode	0 (profile mode), 1 (live mode)
Set general mode	http://[account]:[password]@[IP Address]/request=setGeneralMode&generalMode=[generalMode ID]	generalMode ID: 0 (profile mode), 1 (live mode)
Enable live mode	http://[account]:[password]@[IP Address]/request=enableLiveMode	
Disable live mode	http://[account]:[password]@[IP Address]/request=disableLiveMode	
Get live mode layout	http://[account]:[password]@[IP Address]/request=getLiveLayout	liveLayout: PIP(0), Single(1), Side-by-side(2), Main Speaker(3), Main Speaker(4), Quad View(5)
Set live mode layout	http://[account]:[password]@[IP Address]/request=setLiveLayout&liveLayout=[liveLayout ID]	liveLayout: PIP(0), Single(1), Side-by-side(2), Main Speaker(3), Main Speaker(4), Quad View(5)
Query all profile info	http://[account]:[password]@[IP Address]/request=queryAllProfileTblInfo	response profile data array. array item: { "currentGroup":1, // current group ID "enableVoiceTracking":1, // pause or resume "isCurrent":1, // is current profile "layoutAuto":4, // auto mode layout

		<pre> "layoutManual":3, // manual mode layout "mode":0, // auto mode or manual mode "pid":1, // profile ID 1~36 "profileName":""," // profile name naming by user "profileOrder":1 } </pre>
Get current profile mode	http://[account]:[password]@[IP Address]/request=getMode	auto or manual mode
Set current profile mode	http://[account]:[password]@[IP Address]/request=setMode&mode=[mode ID]	mode ID=0(auto mode), 1(manual mode)
Query device status	http://[account]:[password]@[IP Address]/request=queryOnlineDevice	
Query live mode all layout settings	http://[account]:[password]@[IP Address]/request=queryLiveModeData	<p>response live mode data array.</p> <p>array item:</p> <pre> { "camView":0 // camView: 0 (Single lens camera), 1 (The first lens of multi-lens camera), 2 (The second lens of multi-lens camera), ... "deviceTbCamDid":43, // camera ID "liveModeLayout":1, // layout ID: 0~5 "sourceOrder":1 // source order: 1~4 } </pre>
Reset live mode data	http://[account]:[password]@[IP Address]/request=clearLiveModeData	
Get live mode device list	http://[account]:[password]@[IP Address]/request=queryLiveModeDeviceInfo	<p>response live mode device array.</p> <p>array item:</p> <pre> { "camLensCount":1 // 0(Unknown), 1(Single lens camera), 2(Dual lens camera), ... "deviceTbCamDid":1, // camera ID "name":"USB1", // device name "port":"USB1", // device port or IP address(IP cam) </pre>

		"type": "camera" // device type }
Set camera to live mode layout source	http://[account]:[password]@[IP Address]/request=setLiveModeSource&liveLayout=[liveLayout ID]&srcOrder=[sourceOrder]&camDid=[device Tb CamDid]&camView=[camView Index]	liveLayout ID: 0~5 sourceOrder: 1~4 deviceTbCamDid: camera ID camView: 0(Single lens camera), 1 (The first lens of multi-lens camera), 2 (The second lens of multi-lens camera), ...
RTMP Start streaming	http://[account]:[password]@[IP Address]/cgi-bin?Set=vdo_rtmp_enable, 3, 1	
RTMP Stop streaming	http://[account]:[password]@[IP Address]/cgi-bin?Set=vdo_rtmp_enable, 3, 0	

AVer Control Panel (formerly PTZ Control Panel)

HOME	http://[account]:[password]@[IP Address]/request=ptzHome&camDid=[device Tb CamDid]&camView=[camView Index]	deviceTbCamDid: camera ID camView: 0(Single lens camera), 1 (The first lens of multi-lens camera), 2 (The second lens of multi-lens camera), ...
PanLeftStart	http://[account]:[password]@[IP Address]/request=ptzLeftStart&camDid=[device Tb CamDid]&camView=[camView Index]	deviceTbCamDid: camera ID camView: 0(Single lens camera), 1 (The first lens of multi-lens camera), 2 (The second lens of multi-lens camera), ...
PanLeftStop	http://[account]:[password]@[IP Address]/request=ptzLeftStop&camDid=[device Tb CamDid]&camView=[camView Index]&camView=[camView Index]	deviceTbCamDid: camera ID camView: 0(Single lens camera), 1 (The first lens of multi-lens camera), 2 (The second lens of multi-lens camera), ...
PanRightStart	http://[account]:[password]@[IP Address]/request=ptzRightStart&camDid=[device Tb CamDid]&camView=[camView Index]	deviceTbCamDid: camera ID camView: 0(Single lens camera), 1 (The first lens of multi-lens camera), 2 (The second lens of multi-lens camera), ...
PanRightStop	http://[account]:[password]@[IP Address]/request=ptzRightStop&camDid=[device Tb CamDid]&camView=[camView Index]	deviceTbCamDid: camera ID camView: 0(Single lens camera), 1 (The first lens of multi-lens camera), 2 (The second lens of multi-lens camera), ...
TiltUpStart	http://[account]:[password]@[IP Address]/request=ptzUpStart&camDid=[device Tb CamDid]&camView=[camView Index]	deviceTbCamDid: camera ID camView: 0(Single lens camera), 1 (The first lens of multi-lens camera), 2 (The second lens of multi-lens camera), ...
TiltUpStop	http://[account]:[password]@[IP Address]/request=ptzUpStop&camDid=[device Tb CamDid]&camView=[camView Index]	deviceTbCamDid: camera ID camView: 0(Single lens camera), 1 (The first lens of multi-lens camera), 2 (The second lens of multi-lens camera), ...

TiltDownStart	http://[account]:[password]@[IP Address]/request=ptzDownStart&camDid=[deviceTbCamDid]&camView=[camView Index]	deviceTbCamDid: camera ID camView: 0(Single lens camera), 1 (The first lens of multi-lens camera), 2 (The second lens of multi-lens camera), ...
TiltDownStop	http://[account]:[password]@[IP Address]/request=ptzDownStop&camDid=[deviceTbCamDid]&camView=[camView Index]	deviceTbCamDid: camera ID camView: 0(Single lens camera), 1 (The first lens of multi-lens camera), 2 (The second lens of multi-lens camera), ...
ZoomInStart	http://[account]:[password]@[IP Address]/request=ptzZoomInStart&camDid=[deviceTbCamDid]&camView=[camView Index]	deviceTbCamDid: camera ID camView: 0(Single lens camera), 1 (The first lens of multi-lens camera), 2 (The second lens of multi-lens camera), ...
ZoomInStop	http://[account]:[password]@[IP Address]/request=ptzZoomInStop&camDid=[deviceTbCamDid]&camView=[camView Index]	deviceTbCamDid: camera ID camView: 0(Single lens camera), 1 (The first lens of multi-lens camera), 2 (The second lens of multi-lens camera), ...
ZoomOutStart	http://[account]:[password]@[IP Address]/request=ptzZoomOutStart&camDid=[deviceTbCamDid]&camView=[camView Index]	deviceTbCamDid: camera ID camView: 0(Single lens camera), 1 (The first lens of multi-lens camera), 2 (The second lens of multi-lens camera), ...
ZoomOutStop	http://[account]:[password]@[IP Address]/request=ptzZoomOutStop&camDid=[deviceTbCamDid]&camView=[camView Index]	deviceTbCamDid: camera ID camView: 0(Single lens camera), 1 (The first lens of multi-lens camera), 2 (The second lens of multi-lens camera), ...
FocusInStart	http://[account]:[password]@[IP Address]/request=ptzFocusInStart&camDid=[deviceTbCamDid]&camView=[camView Index]	deviceTbCamDid: camera ID camView: 0(Single lens camera), 1 (The first lens of multi-lens camera), 2 (The second lens of multi-lens camera), ...
FocusInStop	http://[account]:[password]@[IP Address]/request=ptzFocusInStop&camDid=[deviceTbCamDid]&camView=[camView Index]	deviceTbCamDid: camera ID camView: 0(Single lens camera), 1 (The first lens of multi-lens camera), 2 (The second lens of multi-lens camera), ...
FocusOutStart	http://[account]:[password]@[IP Address]/request=ptzFocusOutStart&camDid=[deviceTbCamDid]&camView=[camView Index]	deviceTbCamDid: camera ID camView: 0(Single lens camera), 1 (The first lens of multi-lens camera), 2 (The second lens of multi-lens camera), ...
FocusOutStop	http://[account]:[password]@[IP Address]/request=ptzFocusOutStop&camDid=[deviceTbCamDid]&camView=[camView Index]	deviceTbCamDid: camera ID camView: 0(Single lens camera), 1 (The first lens of multi-lens camera), 2 (The second lens of multi-lens camera), ...
GoPreset	http://[account]:[password]@[IP Address]/request=ptzGoPreset&camDid=[deviceTbCamDid]&presetNum=[preset	deviceTbCamDid: camera ID presetNum: 0~255 camView: 0(Single lens camera), 1 (The

	number]&camView=[camView Index]	first lens of multi-lens camera), 2 (The second lens of multi-lens camera), ...
SavePreset	http://[account]:[password]@[IP Address]/request=ptzSavePreset&camDid=[deviceTbCamDid]&presetNum=[preset number]&camView=[camView Index]	deviceTbCamDid: camera ID presetNum: 0~255 camView: 0(Single lens camera), 1 (The first lens of multi-lens camera), 2 (The second lens of multi-lens camera), ...
GetFocusMode	http://[account]:[password]@[IP Address]/request=ptzGetFocusMode&camDid=[deviceTbCamDid]&camView=[camView Index]	deviceTbCamDid: camera ID focusMode: 0:AF 1:MF -1:NO Focus function device camView: 0(Single lens camera), 1 (The first lens of multi-lens camera), 2 (The second lens of multi-lens camera), ...
SetFocusMode	http://[account]:[password]@[IP Address]/request=ptzSetFocusMode&camDid=[deviceTbCamDid]&focusMode=[0:AF 1:MF]&camView=[camView Index]	deviceTbCamDid: camera ID focusMode: 0:AF 1:MF -1:NO Focus function device camView: 0(Single lens camera), 1 (The first lens of multi-lens camera), 2 (The second lens of multi-lens camera), ...

TCP Commands

A TCP command string starts with AVER:[account]:[password]:/request=X, and ends with \r\n. X is as HTTP requests above. For example, AVER:[account]:[password]:/request=pause\r\n, AVER:[account]:[password]:/request=resume \r\n, and so on.

VISCA Command Table

MT300(N) also can be controlled via below VISCA over IP commands, but does not support VISCA RS-422 commands.

VISCA over IP

PORT

Internet protocol	IPv4
Transport protocol	UDP
Port address	52381

FORMAT

	byte 0	byte 1	byte 2	byte 3	byte 4	byte 5	byte 6	byte 7	byte8 ~~~~	byte23
func	Payload type	Value1	Value2	Payload length 1~16 (0x0001~0x0010)		Sequence number 0X00000000 ~ 0XFFFFFFF			Payload (1 to 16 bytes)	
data									VISCA Packet (see page VISCA)	

Payload type

Name	Value1	Value2	Description
VISCA command	0x01	0x00	Stores the VISCA command.
VISCA inquiry	0x01	0x10	Stores the VISCA inquiry.
VISCA reply	0x01	0x11	Stores the reply for the VISCA command or VISCA inquiry

Sequence number

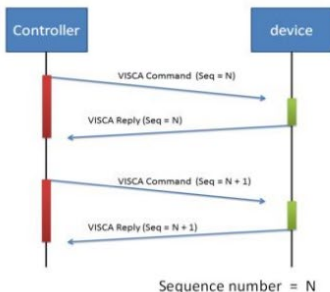

Command Set	Command	Command Packet	Comments	
Power	OFF	8x 01 04 00 03 FF	Power off MT300	
Voice Tracking	Pause	8x 01 04 7D 03 00 FF	Pause voice tracking	
	Resume	8x 01 04 7D 02 00 FF	Resume voice tracking	
System	Change Profile	8x 01 04 40 01 YY FF	YY = profile num(0x01~0x24)	
		8x 01 04 3F 02 YY FF	Preset recall, YY = profile num(0x01~0x24)	
	Reboot	8x 01 04 A4 FF	Reboot MT300	
	Switch Output	USB	8x 01 7E 03 01 FF	USB port 1
			8x 01 7E 03 02 FF	USB port 2

Command samples:

Command Set	Command	Command Packet	Comments
Power	OFF	01 00 00 07 00 00 00 01 81 01 04 00 03 FF	Power off MT300
Voice Tracking	Pause	01 00 00 07 00 00 00 01 81 01 04 7D 03 00 FF	Pause voice tracking